



For 5kV-35kV Distribution Systems

Loadbreak & Deadbreak Separable Connectors

Cable Joints

Cable Termination

Surge Arresters

Fused Elbows



Product Selection Guide

POWER DELIVER



INTRODUCTION

Product Guide PG-CA provides an easy-to-use, comprehensive listing of ELASTIMOLD products for 5kV thru 35kV underground power distribution systems. Included are separable elbow connectors, cable joints, terminations, surge arresters, fused elbows and other cable accessory components. The catalog incorporates information relative to product application, ratings and selection.

ELASTIMOLD is recognized as the leading producer of premolded cable accessory components worldwide. Utilizing specially formulated materials with 100% peroxide-cured insulation and shielding, Elastimold products represent the state-of-the-art in premolded process technology. Durable, quality construction and non-degrading, high-reliability, maintenance-free performance is assured when specifying ELASTIMOLD products.

ELASTIMOLD's broad line of premolded products offers significant advantages over field-fabricated and other alternatives, including: 100% factory assurance testing prior to delivery and installation; simplified, single-piece construction with built-in insulating, shielding and sealing surfaces; ease of installation with no special skills or tools required; and compact, lightweight, durable designs for easy handling and application.

Separable Elbow Connectors and their related accessories are available in 200 Amp loadbreak, 200 Amp deadbreak and 600 Amp deadbreak styles. Rated for padmount, subsurface, vault, indoor, outdoor and other applications, units feature interchangeable interfaces which can be easily engaged or separated to provide a convenient method to connect or disconnect cable and equipment to the distribution system.

Cable Joints are available in permanently crimped or bolted (separable) connector styles. Permanently crimped units are rated the same as the cable they are connecting and are available for all applications including direct buried.

Cable Terminations are available in single-piece or modular designs. Rated for indoor, outdoor or padmount applications, units allow connection and transition from shielded underground cables to bare overhead conductors and live-front equipment.

Surge Arresters are constructed using metal oxide blocks for overvoltage protection and 200 Amp separable connector interfaces for attachment to other ELASTIMOLD accessories.

Fused Elbows combine replaceable current-limiting fuses for overcurrent protection and 200 Amp separable connector interfaces for attachment to other ELASTIMOLD accessories.

Elastimold Special Component Services Group provides custom products tailored to specific application requirements. Please contact the factory for further information regarding this service.

DEADFRONT	SEPARABLE CONNECTORS	200 AMP LOADBREAK	5-15kV	PART #	
LIVEFRONT	FUSED ELBOWS	200 AMP DEADBREAK	25kV		
	CABLE JOINTS	600 SERIES DEADBREAK	35kV		
	TERMINATIONS				
	SURGE ARRESTERS				

Part numbers that contain the letters **W** or **X** are size sensitive. To complete the part number, refer to the **W** or **X** tables indicated.

COMPONENT APPLICATION AND SELECTION

Product Guide PG-CA includes component group schematics, part numbers and standard ratings of ELASTIMOLD products for application on underground power distribution systems utilizing solid dielectric cable. Go directly to the product section in the table of contents or follow the decision path outlined below for component selection and application.

DEADFRONT	SEPARABLE CONNECTORS
LIVEFRONT	FUSED ELBOWS
	CABLE JOINTS
	TERMINATIONS
	SURGE ARRESTERS

200 AMP LOADBREAK
200 AMP DEADBREAK
600 SERIES DEADBREAK

- Determine if the application involves **Deadfront** (shielded) or **Livefront** (unshielded) connections. Terminations are air insulated and classified as Livefront.
- Determine if the application requires **Separable Connectors, Fused Elbows, Cable Joints, Terminations** or **Surge Arresters**.
- If Separable Connectors are involved, determine the required current class: **200 Amp, 600 Amp** or **900 Amp**. This decision is based on the conductor size, loading, and system short circuit currents. The selected connector must be compatible with the mating interface on any equipment.
- 200 Amp connectors are available in **Loadbreak** and **Deadbreak** styles. Determine which style is required. 600 Series Connectors are Deadbreak only and Fused Elbows are Loadbreak only.
- Determine the part number related to the specific **Voltage Class** by utilizing the schematic layouts and product tables.
- If the component mates with cable, determine the cable insulation diameter, conductor size, type of cable shield and if jacket sealing is required.

5-15kV
25kV
35kV

PART #

TABLE OF CONTENTS

• Certified Tests and Performance	2	• Cable Terminations.....	24 – 27
• Separable Connector Interfaces	3	• Surge Arresters	28, 29
• 200 Amp Loadbreak Connectors	4 – 7	• Shield Adapters, Grounding Kits & Jacket Seals.....	30, 31
• 200 Amp Deadbreak Connectors.....	8, 9	• How to specify size-sensitive products.....	32, 33
• 600 Series Deadbreak Connectors	10 – 13	• WX Size Tables.....	34, 35
• 600 Series Deadbreak Connectors – Cam-Op, Link-Op	14, 15	• AEIC and ICEA Cable Insulation Diameter Reference	36 – 39
• 600 Series Deadbreak Connectors – Stick-Op, Window-Op.....	16, 17	• Cable Conductor Diameter Reference	40
• 600 Series Deadbreak Cable Joints	18, 19	• Equipment Bushings	41
• Molded Multi-Point Junctions.....	20, 21	• Index.....	42 – 44
• PCJ Cable Joints	22, 23		

CERTIFIED TESTS AND PERFORMANCE

Elastimold Separable Connectors, Cable Joints, Cable Terminators, Surge Arresters, Fused Elbows and other cable accessory products have been designed and tested per applicable portions of IEEE, ANSI, NEMA and other industry standards including:

- IEEE 386™ Standard For Separable Connectors
- IEEE 404™ Standard For Cable Joints and Splices
- IEEE 48™ Standard For Cable Terminations

- IEEE C62.11™ Standard For Metal Oxide Surge Arresters
- ANSI C37.41 Standard For Current Limiting Fuses
- IEEE 592™ Standard For Exposed Semiconducting Shields
- ANSI C119.4 Standard For Copper and Aluminum Conductor Connectors
- AEIC CS6 and CS8 Standards For XLP and EPR Insulated Cables
- ICEA S-97-682-2000 Utility Shielded Power Cables Rated 5,000 – 46,000 Volts

CABLE JOINTS, TERMINATIONS AND ARRESTER RATINGS

Refer to the pages listed below for rating information:

- PCJ Cable Joints, page 22.
- Cable Terminations, page 24.
- Surge Arresters, page 28.

SEPARABLE CONNECTOR RATINGS

Table 1 shows voltage and current ratings which apply to all Separable Connectors including 200 AMP Loadbreak, 200 AMP Deadbreak and 600 Series Deadbreak products. Table 2 shows switching and fault close ratings which only apply to 200 AMP Loadbreak Connectors.

TABLE 1	15kV Class Ratings	25kV Class Ratings	35kV Class Ratings
<ul style="list-style-type: none"> • OPERATING VOLTAGE Maximum line-to-ground (See Application Info Note 1) 	8.3kV	15.2kV	21.1kV
<ul style="list-style-type: none"> • BIL Impulse withstand 1.2 x 50 microsecond wave 	95kV	125kV	150kV
<ul style="list-style-type: none"> • WITHSTAND VOLTAGE AC One Minute DC Fifteen Minute 	34kV 53kV	40kV 78kV	50kV 103kV
<ul style="list-style-type: none"> • CORONA EXTINCTION LEVEL @ 3pC Sensitivity 	11kV	19kV	26kV
200 AMP Products Continuous Current: Symmetrical Momentary Current: 600 Series Products Continuous Current: Symmetrical Momentary Current:	200 AMP* 10kA sym, 10 cycle duration 600 and 900 AMP* 25kA sym, 10 cycle duration * Designed for 90° C maximum continuous operating temperature		

TABLE 2	LOADMAKE/LOADBREAK SWITCHING	FAULT CLOSE
15kV Class Ratings	<ul style="list-style-type: none"> • 1ϕ and 3ϕ circuits 8.3kV line to ground, 14.4kV max. across open contacts. • 10 loadmake/break operations at 200 Amps max. with 70 to 80% lagging power factor. 	1 fault close operation at 8.3kV or 14.4kV; 10,000 Amps, rms, sym. 10 cycles (0.17 sec.) 1.3 max. asym factor applies to new or used mating parts (up to maximum designated switching operations.)
25kV Class Ratings	<ul style="list-style-type: none"> • 1ϕ and 3ϕ circuits 15.2kV line to ground, 26.3kV max. across open contacts. • 10 loadmake/break operations at 200 Amps max. with 70 to 80% lagging power factor. 	1 fault close operation at 15.2kV or 26.3kV; 10,000 Amps, rms, sym. 10 cycles (0.17 sec.) 1.3 max. asym factor applies to new or used mating parts (up to maximum designated switching operations.)
35kV Class Ratings	<ul style="list-style-type: none"> • 1ϕ and 3ϕ circuits 21.1kV line to ground, 36.6kV max. across open contacts. • 10 loadmake/break operations at 200 Amps max. with 70 to 80% lagging power factor. 	1 fault close operation at 21.1kV or 36.6kV; 10,000 Amps, rms, sym. 10 cycles (0.17 sec.) 1.3 max. asym factor applies to new or used mating parts (up to maximum designated switching operations.)

Application Information:







1. Loadbreak connectors are designed and rated for use on grounded WYE systems. For application on ungrounded WYE or delta systems, the next higher voltage class product is recommended. Examples: 5kV ungrounded: use 15kV class products; 15kV ungrounded: use 25kV class products; 25kV ungrounded: use 35kV class products; 35kV ungrounded: contact factory.
2. Products are designed and constructed for all applications including padmount, subsurface, vault, indoor, outdoor, direct sunlight, direct buried and continuously submerged in water.
3. Products are designed and rated for ambient temperatures of -40° C to +65° C. It is recommended that loadbreak connectors be hotstick operated at -20° C to +65° C ambient temperature range and at altitudes not exceeding 6000 feet.

SEPARABLE CONNECTOR INTERFACES

STANDARD INTERFACES FOR SEPARABLE CONNECTORS, COMPONENTS AND EQUIPMENT BUSHINGS

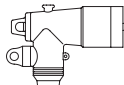
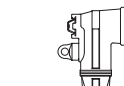
ANSI/IEEE Standard 386 defines the specific interface dimensions that 200 Amp and 600 Series elbows, inserts, junctions, equipment bushings and any mating components must conform to insure interchangeability. The table

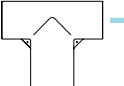
below provides information concerning the types of interfaces supplied by Elastimold for various applications and is useful to assure proper matching of components.

	Bushing Interface	Voltage Class	Interface Description	Standard No. Figure No.
	A 200 AMP DEEPWELL EQUIPMENT BUSHING	15kV, 25kV and 35kV	200 AMP Bushing Well Interface 8.3kV, 15.2kV, 21.1kV	A IEEE 386-2001 Fig. 3
	B 200 AMP LOADBREAK INSERT	15kV	200 AMP Loadbreak 8.3kV and 8.3kV/14.4kV	B IEEE 386-2001 Fig. 5
	C 200 AMP LOADBREAK INSERT	25kV	200 AMP Loadbreak 15.2kV and 15.2kV/26.3kV	C IEEE 386-2001 Fig. 7, Note 3
	D 200 AMP LOADBREAK INSERT	35kV	200 AMP Loadbreak Interface No. 2 21.1kV and 21.1kV/36.6kV	D IEEE 386-2001 Fig. 7, Note 3
	E 200 AMP DEADBREAK INSERT	15kV and 25kV	200 AMP Deadbreak 8.3kV and 15.2kV	E IEEE 386-2001 Fig. 4
	F 600 SERIES EQUIPMENT BUSHING	15kV and 25kV	600 AMP Deadbreak Interface No.1 8.3kV and 15.2kV	F IEEE 386-2001 Fig.11, Note 1
	G 600 SERIES EQUIPMENT BUSHING	35kV	600 AMP Deadbreak Interface No.1 21.1kV	G IEEE 386-2001 Fig.13, Note 2

NOTES:

1. Was Fig. 10 in previous IEEE 386-2001 publication.
2. Was Fig. 11 in previous IEEE 386-2001 publication.
3. Elastimold uses Fig. 7 interface for both 25 and 35kV applications.

SEPARABLE CONNECTORS 200 AMP LOADBREAK

200 Amp loadbreak connectors and accessories provide a convenient method to connect/disconnect cable and equipment on power distribution systems. Loadbreak elbows include provisions for energized operation using standard hotstick tools, allowing load-make/break operation and a visible disconnect. Components can be isolated with insulated caps, plugs and parking bushings.

Optional accessories allow system grounding, testing, bypass, lightning surge protection and current limiting fusing. Additional connecting points and taps can be provided by use of junctions or feed-thrus.

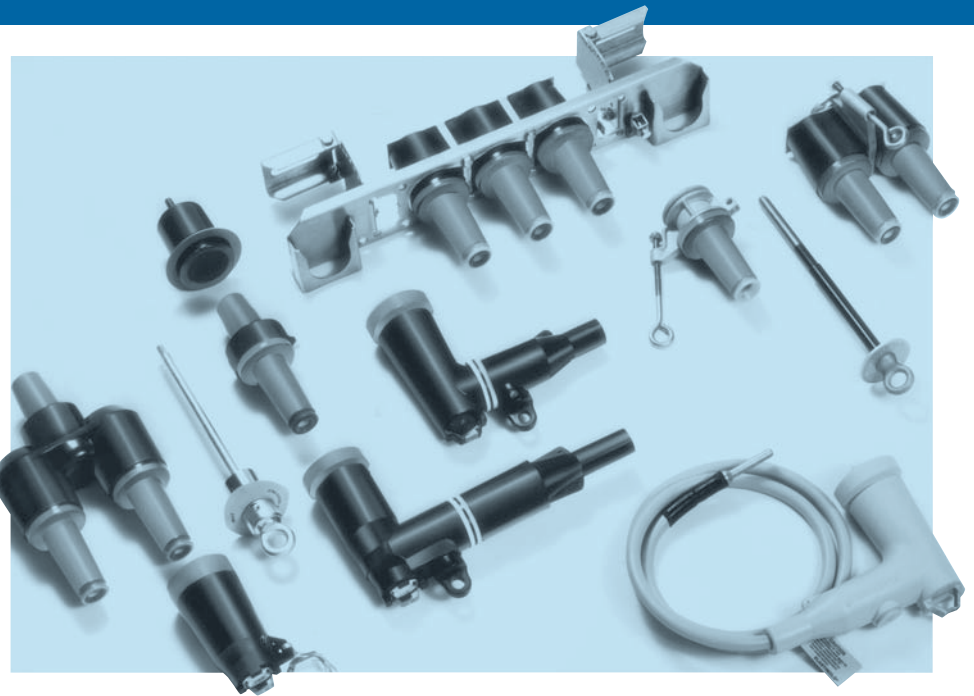

RATINGS OVERVIEW

See page 2 for complete information including switching and fault close ratings.

CURRENT RATINGS

200A Continuous
10kA sym. 10 Cycles

VOLTAGE RATINGS

15kV Class
8.3kV Phase-to-Ground
14.4kV Phase-to-Phase
95kV BIL
34kV AC Withstand
53kV DC Withstand
11kV Corona Extinction

25kV Class

15.2kV Phase-to-Ground
26.3kV Phase-to-Phase
125kV BIL
40kV AC Withstand
78kV DC Withstand
19kV Corona Extinction

35kV Class

21.1kV Phase-to-Ground
36.6kV Phase-to-Phase
150kV BIL
50kV AC Withstand
103kV DC Withstand
26kV Corona Extinction

200 AMP LOADBREAK SEPARABLE CONNECTOR COMPONENTS

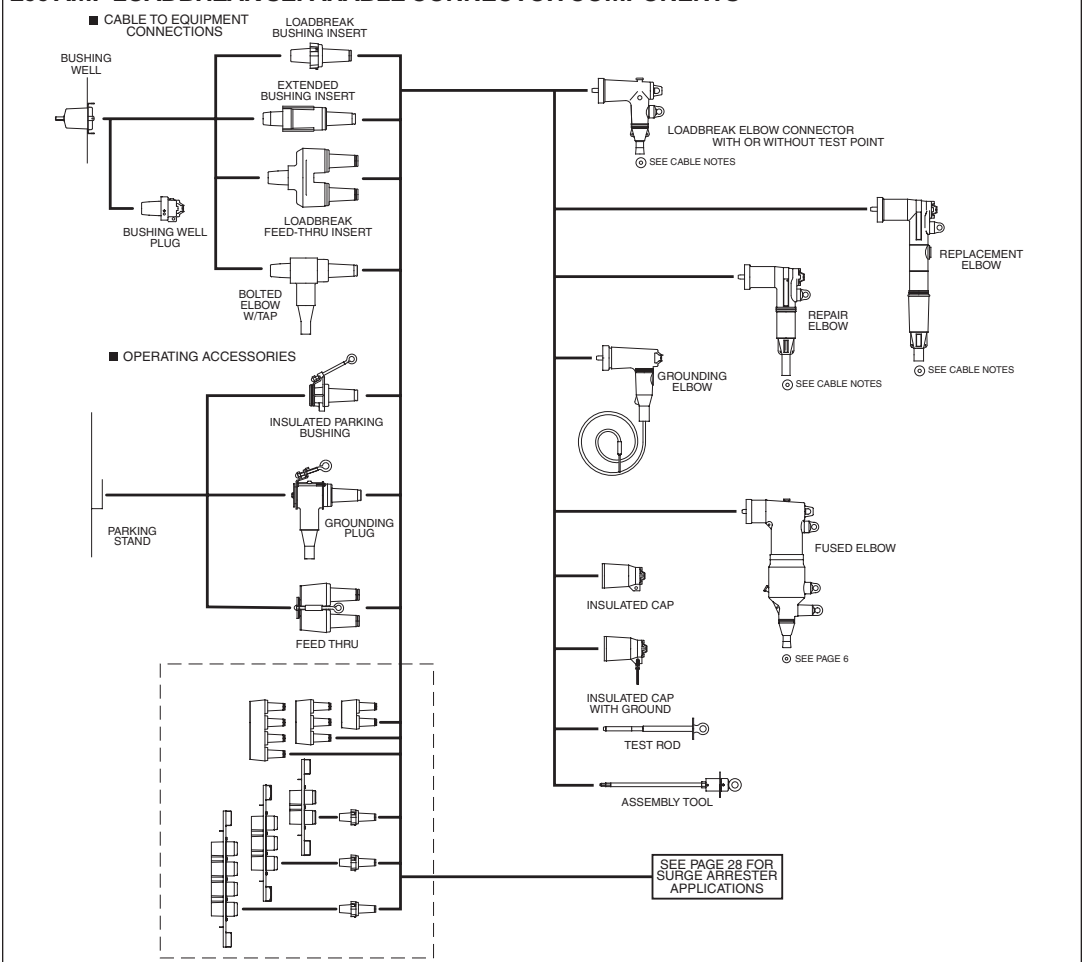

SEPARABLE CONNECTORS		200 AMP LOADBREAK	5-15kV	PART #
DEADFRONT	FUSED ELBOWS	200 AMP DEADBREAK	25kV	
LIVEFRONT	CABLE JOINTS	600 SERIES DEADBREAK	35kV	
	TERMINATIONS			
	SURGE ARRESTERS			

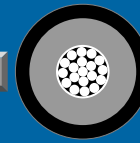

Part numbers that contain the letters **W** or **X** are size sensitive. To complete the part number, refer to the **W** or **X** tables indicated.

200 AMP LOADBREAK

Illustration (not to scale)	Description	Voltage Class	ELASTIMOLD Part Number	Notes
	Elbow Connector	15kV	165LR-W5X Use Tables W1 and X1	N2,3,4,5
		25kV	275LR-W5X Use Tables W16 and X1	N2,3,4,5
		35kV	375LR-W5X Use Tables W3 and X2	N2,3,5
	Elbow Connector w/ Test Point	15kV	166LR-W5X Use Tables W1 and X1	N2,3,4,5
		25kV	276LR-W5X Use Tables W16 and X1	N2,3,4,5
		35kV	376LR-W5X Use Tables W3 and X2	N2,3,5
	Jacket Seal Elbow Connector	15kV	165LRJS-W5X Use Table W1 (B&C sizes only) and Table X1	N2,19
		25kV	275LRJS-W5X Use Tables W16 and X1	N2,19
	Jacket Seal Elbow Connector w/ Test Point	15kV	166LRJS-W5X Use Tables W1 (B&C sizes only) and Table X1	N2,19
		25kV	276LRJS-W5X Use Tables W16 and X1	N2,19
	Repair Elbow Connector	15kV	167ELR-W5X Use Tables W5 and X1	N5,10,18
		25kV	273ELR-W5X Use Tables W5 and X1	N5,10,18
	Repair Elbow Connector w/ Test Point	15kV	168ELR-W5X Use Tables W5 and X1	N5,10,18
		25kV	274ELR-W5X Use Tables W5 and X1	N5,10,18
	Replacement Elbow	15kV	167RLR-W5X Use Tables W4 and X1	N5,11,13
		25kV	273RLR-W5X Use Tables W2 and X1	N5,11,13
	Replacement Elbow w/ Test Point	15kV	168RLR-W5X Use Tables W4 and X1	N5,11,13
		25kV	274RLR-W5X Use Tables W2 and X1	N5,11,13
	Fused Elbow (General Purpose Current Limiting)	15kV	168FLR H-W0X	N5,15
		25kV	274FLR H-W0X Use W and X Tables on Page 6	
	Bolted Elbow w/ Tap	15kV	167LRT-W5X Use Tables W4 and X1	N17
	Bushing Insert	15kV	1601A4	N4,8,20
		25kV	2701A4	
		35kV	3701A4 3701A3	
	Extended Bushing Insert	15kV	1601EA4	N8,20
		25kV	2701EA4	
	Feed-Thru Insert	15kV	1602A3R	N16
		25kV	2702A1	
		35kV	3702A1	
	Insulated Cap	15kV	160DR	N9
	Insulated Cap w/ Ground	15kV	160DRG	N9
		25kV	167DRG	
		35kV	273DRG 375DRG	
	Insulated Cap w/ Ground and Test Point	15kV	168DRG	N7
		25kV	274DRG	
		35kV	376DRG	

Illustration (not to scale)	Description	Voltage Class	ELASTIMOLD Part Number	Notes
	Grounding Plug (1/0 AWG x 6' Ground Lead)	15kV 25kV	161GP 272GP	
	Grounding Elbow (1/0 AWG x 6' Ground Lead)	15kV 25/35kV	160GLR 370GLR	N12
	Feed-Thru	15kV 25kV 35kV	164FT 274FT 373FT	
		Feed-Thru Vertical	15kV 25kV 35kV	164FTV 274FTV 373FTV
	Feed-Thru Well	15/25kV	K1601WFT	
		Feed-Thru Well Vertical	15/25kV	K1601WFTV
	Insulated Parking Bushing	15kV	161SOP	N20 N20
		25kV	272SOP	
		35kV	372SOP	
	Test Rod	ALL	370TR	
	Bushing Well Plug	15/25kV 35kV	276BWP M276BWP	
		Assembly Tool	ALL	200AT

- N1. Copper lug for use on COPPER CONDUCTOR ONLY.
- N2. W5X indicates that the part number includes 02500X long bi-metal compression lug as standard. For an all-copper lug, replace W5X with W2X in Table X1 to specify the all-copper 02702X lug.
- N3. Also available as housing only. Specify: 165BLR-W; 275BLR-W; 375BLR-W; 166BLR-W; 276BLR-W; 376BLR-W.
- N4. Also available as elbow/insert combination. Specify: 165A4-WX; 275A4-WX; 166A4-WX; 276A4-WX.
- N5. Also available with 200ECS jacket seal included. Add - "S" suffix to part number.
- N6. Rated for single-phase applications only.
- N7. Equipped with insulated cuff.
- N8. Includes internal torquing feature using 200AT Assembly Tool.
- N9. Also available without probe. Specify "A" suffix - Example: 273DRGA.
- N10. Repair elbow has extended length contact and elbow housing resulting in a net gain of 3-1/4" in length.
- N11. Replacement elbow has extended length contact and elbow housing resulting in a net gain of 8-7/8" in length.
- N12. Rated for 25kV thru 35kV applications.
- N13. Includes long bi-metal contact 00400X.
- N14. 160CA Cable Size Adapter can only be used with elbow part numbers 165LR/166LR C size only.
- N15. See page 6 for WX size tables and for fuse sizes.
- N16. Fully rotatable for 360° positioning. Includes bail assembly to secure feed-thru insert to bushing well.
- N17. Includes 02800X bi-metal contact.
- N18. Includes 02509X long bi-metal contact.
- N19. Includes built-in jacket seal. Also available as housing only — specify: 165BLRJS-W, 166BLRJS-W, 275BLRJS-W or 276LRJS-W. Also available as elbow/insert combination — specify: 165JSA4-W5X, 166JSA4-W5X, 275JSA4-W5X or 276JSA4-W5X.
- N20. Includes a yellow seating indicator and vent ring.
- N21. Includes a black vent ring.

	<p>CONTACTS, PROBES, PLUGS, CABLE ADAPTERS AND JUNCTIONS</p> <p>CONTINUED ON PAGE 7.</p>
--	--

Refer to the **W** and **X** tables on pages 34 and 35 for sizing to cable insulation diameter and conductor size.
For cable shield adapters and jacket seals, see page 30.

SEPARABLE CONNECTORS

200 AMP LOADBREAK Cont'd from Pg. 5

RATINGS OVERVIEW

See page 2 for complete information including switching and fault close ratings.

CURRENT RATINGS

200A Continuous
10kA sym. 10 Cycles

VOLTAGE RATINGS

15kV Class
8.3kV Phase-to-Ground
14.4kV Phase-to-Phase
95kV BIL
34kV AC Withstand
53kV DC Withstand
11kV Corona Extinction

25kV Class

15.2kV Phase-to-Ground
26.3kV Phase-to-Phase
125kV BIL
40kV AC Withstand
78kV DC Withstand
19kV Corona Extinction

35kV Class

21.1kV Phase-to-Ground
36.6kV Phase-to-Phase
150kV BIL
50kV AC Withstand
103kV DC Withstand
26kV Corona Extinction

200 AMP LOADBREAK SEPARABLE CONNECTOR COMPONENTS

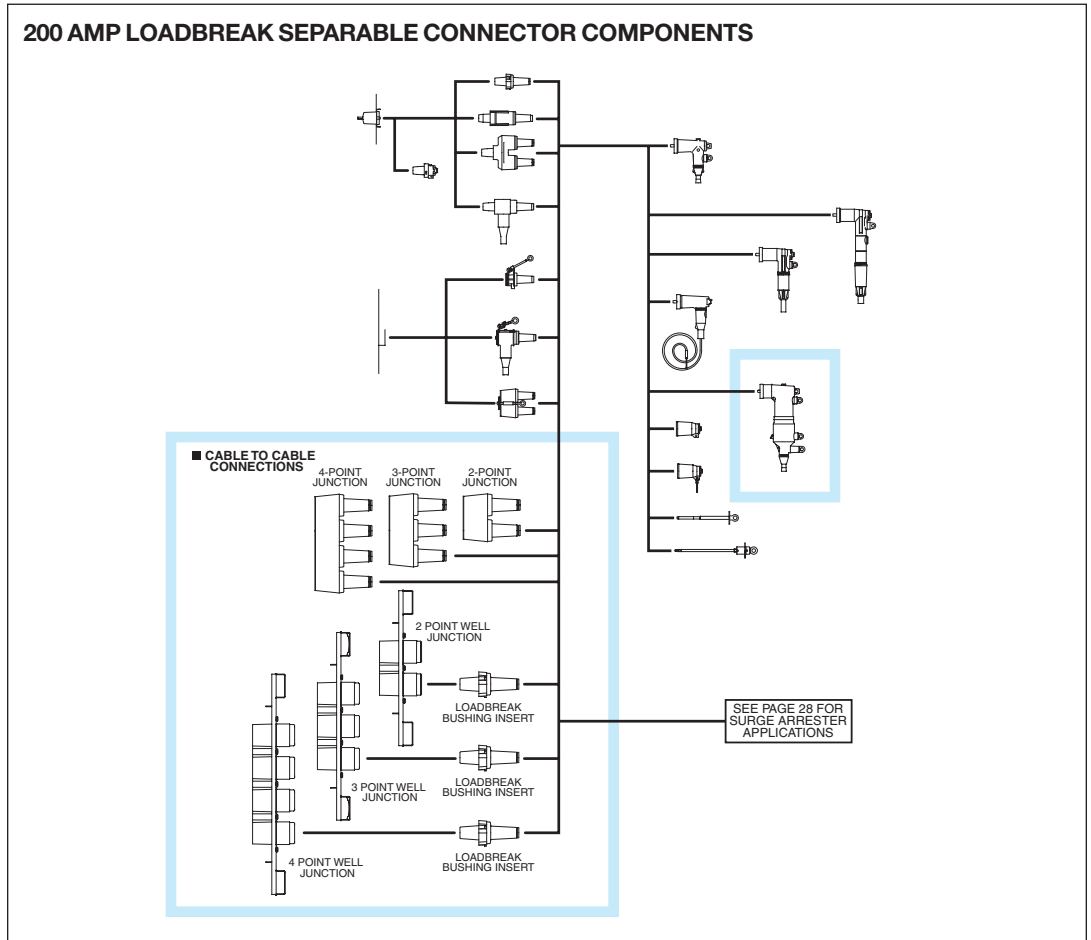

FUSED ELBOW ORDERING INSTRUCTIONS

The following graph shows how to select the catalog number for the fuse housing.

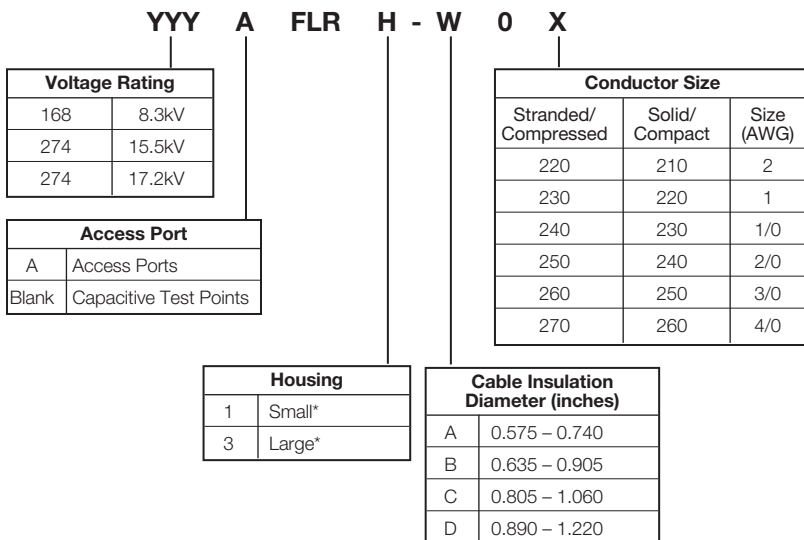

*Small Housing is used with 8.3 and 15.5kV rated fuses.
Large Housing is used with 17.2kV rated fuses.

ORDERING INSTRUCTIONS FOR FUSE KIT (to be ordered separately)

The following graph shows how to select the catalog number for the full range current limiting fuse.

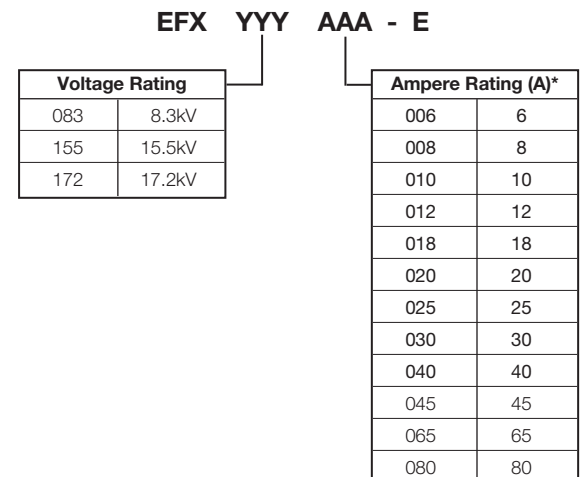

* 8.3kV rated are available in all Amp ratings listed.
15.5kV fuse sizes are available between 6 – 20 Amp.
17.2kV fuse sizes are available between 6 – 45 Amp.

SEPARABLE CONNECTORS		200 AMP LOADBREAK	5-15kV	PART #
DEADFRONT	FUSED ELBOWS	200 AMP DEADBREAK	25kV	
LIVEFRONT	CABLE JOINTS	600 SERIES DEADBREAK	35kV	
	TERMINATIONS			
	SURGE ARRESTERS			

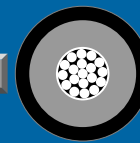

Part numbers that contain the letters **W** or **X** are size sensitive. To complete the part number, refer to the **W** or **X** tables indicated.

200 AMP LOADBREAK

Illustration (not to scale)	Description	Voltage Class	ELASTIMOLD Part Number	Notes
	Contacts: Long Bi-Metal ELR Bi-Metal Copper LRT Contact RLR Contact	ALL 15/25kV ALL 15kV 15/25kV	Use Table X1 02500X 02509X 02702X 02800X 00400X	N1 N2 N3
	Elbow Probe	15kV 25kV 35kV	166LRF 274LRF 375LRF	
	Elbow Cable Entrance Insulating Plug	ALL	10EPW Use Table W6	
	Cable Size Adapter	15kV	160CA-W Use Table W6 EB-FA Only	N4
	2-Way Well Junction w/ s.s. Bracket	15/25kV	K1601WJ2	N6
	2-Way Well Junction w/ "U" Straps	15/25kV	K1601WJ2-5	N5, 6, 11
	3-Way Well Junction w/ s.s. Bracket	15/25kV	K1601WJ3	N6
	3-Way Well Junction w/ "U" Straps	15/25kV	K1601WJ3-5	N5, 6, 12
	4-Way Well Junction w/ s.s. Bracket	15/25kV	K1601WJ4	N6
	4-Way Well Junction w/ "U" Straps	15/25kV	K1601WJ4-5	N5, 6, 13
	2-Point Junction with/stainless steel bracket	15kV 25kV 35kV	164J2 274J2 373J2	N7 N7 N7
	2-Point Junction w/"U"-straps	15kV 25kV 35kV	164J2-5 274J2-5 373J2-5	N5, 8 N5, 11 N5, 11
	3-Point Junction with/stainless steel bracket	15kV 25kV 35kV	164J3 274J3 373J3	N7 N7 N7
	3-Point Junction w/"U"-straps	15kV 25kV 35kV	164J3-5 274J3-5 373J3-5	N5, 9 N5, 12 N5, 12
	4-Point Junction with/stainless steel bracket	15kV 25kV 35kV	164J4 274J4 373J4	N7 N7 N7
	4-Point Junction w/"U"-straps	15kV 25kV 35kV	164J4-5 274J4-5 373J4-5	N5, 10 N5, 13 N5, 13

- N1. Repair elbow has extended length contact and elbow housing resulting in a net gain of 3-1/4" in length.
- N2. Copper lug for use on COPPER CONDUCTOR ONLY.
- N3. Replacement elbow has extended length contact and elbow housing resulting in a net gain of 8-7/8" in length.
- N4. 160CA Cable Size Adapter can only be used with elbow part numbers 165LR/166LR C size only.
- N5. Also available as rubber only, without straps. Specify suffix "-4" in place of "-5" in the part number.
- N6. Supplied with replaceable stud. Replacement stud available separately. Specify 1601RS.
- N7. Hardware packages, consisting of brackets & straps only, may be ordered separately by specifying "-6" in the part number. Example 164J4-6
- N8. Hardware package, consists of "U"-straps and back plate only, may be ordered separately by specifying 1601US-J2.
- N9. Hardware package, consists of "U"-straps and back plate only, may be ordered separately by specifying 1601US-J3.
- N10. Hardware package, consists of "U"-straps and back plate only, may be ordered separately by specifying 1601US-J4.
- N11. Hardware package, consists of "U"-straps and back plate only, may be ordered separately by specifying 271-68.
- N12. Hardware package, consists of "U"-straps and back plate only, may be ordered separately by specifying 271-61.
- N13. Hardware package, consists of "U"-straps and back plate only, may be ordered separately by specifying 271-70.

SEPARABLE CONNECTORS 200 AMP DEADBREAK

200 Amp deadbreak connectors and accessories provide a quick disconnect feature for cable and equipment connections on power distribution systems. All deadbreak connectors must be DE-ENERGIZED before operating and must be mechanically secured with bails when connected. Components can be isolated with insulated caps, plugs and parking bushings.

All deadbreak elbows are equipped with test points as standard. Optional accessories allow system grounding, bypass and lightning surge protection. Additional connecting points and taps can be provided by use of junctions or feed-thrus.

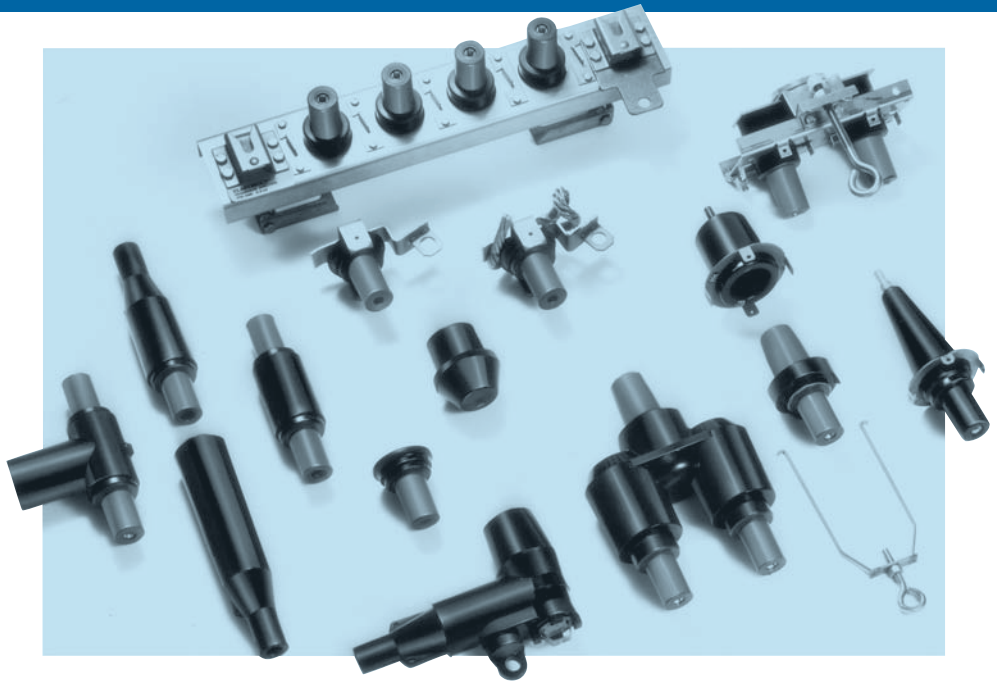

RATINGS OVERVIEW

See page 2 for complete information.

CURRENT RATINGS

200A Continuous
10kA sym. 10 Cycles

VOLTAGE RATINGS

15kV Class
8.3kV Phase-to-Ground
14.4kV Phase-to-Phase
95kV BIL
34kV AC Withstand
53kV DC Withstand
11kV Corona Extinction

25kV Class

15.2kV Phase-to-Ground
26.3kV Phase-to-Phase
125kV BIL
40kV AC Withstand
78kV DC Withstand
19kV Corona Extinction

200 AMP DEADBREAK SEPARABLE CONNECTOR COMPONENTS

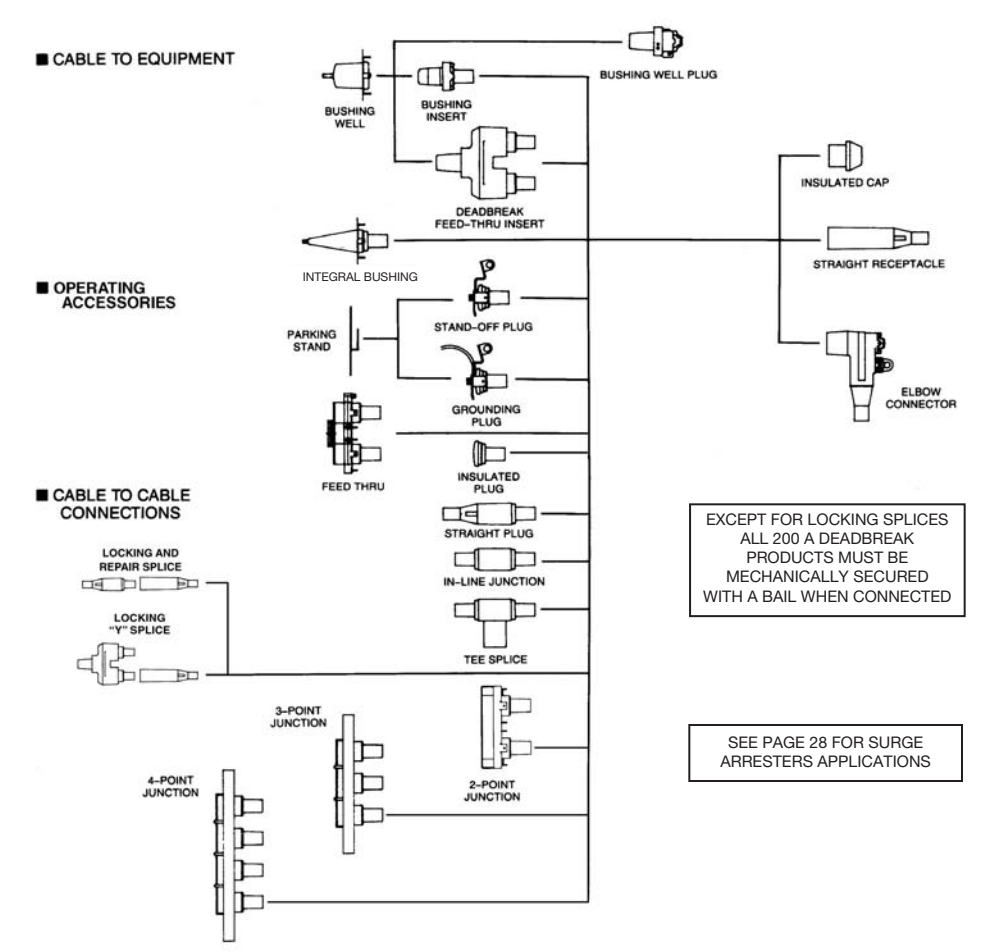

SEPARABLE CONNECTORS		200 AMP LOADBREAK	5-15kV
DEADFRONT	FUSED ELBOWS	200 AMP DEADBREAK	25kV
LIVEFRONT	CABLE JOINTS	600 SERIES DEADBREAK	35kV
	TERMINATIONS		
	SURGE ARRESTERS		

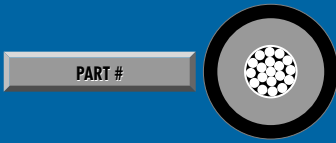

Part numbers that contain the letters **W** or **X** are size sensitive. To complete the part number, refer to the **W** or **X** tables indicated.

200 AMP DEADBREAK

Illustration (not to scale)	Description	Voltage Class	ELASTIMOLD Part Number	Notes
	Elbow Connector w/ Test Point	15/25kV	156LR-W5X Use Tables W4 and X1	N1,2
	Bail Assembly for 156LR Elbow	15/25kV	150BA	
	Bushing Insert	15/25kV	K1501A1	N3
	Feed-thru Insert	15/25kV	K1502A1	N3,4
	Insulated Plug	15/25kV	K150DP	N3
	Insulated Cap	15/25kV	K150DR	N3
	Insulated Parking Bushing	15/25kV	K151SOP	N3
	Grounding Plug	15/25kV	151GP	N3
	Feed-Thru	15/25kV	K1501FT	N3,6
	2-Point Junction	15/25kV	K1501J2-U	N3,6
	3-Point Junction	15/25kV	K1501J3-U	N3,6
	4-Point Junction	15/25kV	K1501J4-U	N3,6
	Elbow Probe	15/25kV	156LRF	
	Straight Receptacle	15/25kV	K151SR-W0X Use Tables W1A and X1	N3,12,13,17
	Straight Plug	15/25kV	K151SP-W0X Use Tables W1A and X1	N3,12,13
	Tee Splice	15/25kV	K150T	N3
	In-Line Junction	15/25kV	K150S	N3
	Locking Splice/Repair Splice	15/25kV	K151LS-W1X Use Tables W1A and X1	N8,9,13,15,16,17,20
	Locking "Y" Splice	15/25kV	K151LY-W1X Use Tables W1A and X1	N8,9,13,15,17,21
	BAIL	15/25kV	150TB1	N5
	BAIL	15/25kV	150TB2	N5
	BAIL	15/25kV	150TB3	N5

Illustration (not to scale)	Description	Voltage Class	ELASTIMOLD Part Number	Notes
	BAIL	15/25kV	150TB4	N5
	BAIL	15/25kV	150TB5	N5
	Contacts: Long Bi-Metal Copper	15/25kV 15/25kV	02500X 02702X	N7
	Elbow Cable Entrance Insulating Plug	15/25kV	10EP-W Use Table W6	N10
	Cable Entrance Insulating Plug	15/25kV	152EA-W Use Table W6	N11
	Cable Size Adapter	15/25kV	160CA-W Use Table W6 EB-FA Only	N14

- N1. Includes bail assembly.
- N2. W5X indicates that the part number includes a 02500X bi-metal compression lug, which is rated for either aluminum or copper conductor, as standard. For an all-copper lug, replace W5X with W2X in Table X1 to specify the all-copper 02702X lug.
- N3. Bails are required but not included. Order separately. Consult factory for bails not listed for a specific application.
- N4. Fully rotatable for 360° positioning. Includes bail assembly to secure feed-thru insert to bushing well. Elbows bail assemblies are required but not included with the feed-thru insert.
- N5. Refer to factory for application details.
- N6. Center-to-center spacing equals 4 inches.
- N7. Copper lug for copper cable only.
- N8. To order cable legs for different cable sizes, list each leg size "W" and "X". Example: K151LY-A1240-A1240-B1220. See Tables W1 and X1 for sizes.
- N9. To order locking contacts for K151LS and K151LY, order 01401X (Al) or 01402X (Cu) for plug contact. Order 01301X (Al) or 01302X (Cu) for receptacle. See Table X1 for sizes.
- N10. For use with 156LR elbows.
- N11. For use with K151SR, K151SP, K151LS, K151LY receptacles, plugs and splices.
- N12. Also available as housing only. Specify K151BSP-W or K151BSR-W.
- N13. Also available in EB-FA sizes per table W6 by using 160CA cable adapter with C size plugs & receptacles.
- N14. 160CA cable adapter can only be used with C size plugs & receptacles.
- N15. Bails are not required for locking splices.
- N16. When used as a repair splice, the assembled length allows 4" for cable-replacement/repair.
- N17. Straight receptacles are also available with test point. Specify K152SR-W0X part number.
- N18. W0X indicates that the part number includes a 01500X universal aluminum compression lug, which is rated for either aluminum or copper, as standard. For an all-copper lug, replace W0X with W2X in Table X1 to specify the all-copper 01502X lug.
- N19. W0X indicates that the part number includes a 01600X universal aluminum compression lug, which is rated for either aluminum or copper, as standard. For an all-copper lug, replace W0X with W2X in Table X1 to specify the all-copper 01602X lug.
- N20. W1X indicates that the part number includes a 01401X aluminum compression lug, which is rated for aluminum only, as standard. For an all-copper lug, replace W1X with W2X in Table X1 to specify the all-copper 01402X lug.
- N21. W1X indicates that the part number includes a 01301X aluminum compression lug, which is rated for aluminum only, as standard. For an all-copper lug, replace W1X with W2X in Table X1 to specify the all-copper 01302X lug.

Refer to the **W** and **X** tables on pages 34 and 35 for sizing to cable insulation diameter and conductor size.
For cable shield adapters and jacket seals, see page 30.

SEPARABLE CONNECTORS 600 SERIES DEADBREAK

600 Series deadbreak elbows, straight receptacles, junctions, vault stretchers and accessories are used to connect equipment and cable on primary feeder and network circuits. Designs accommodate large conductors and feature bolted connections and deadfront modular construction for maximum reliability, performance and versatility.

DE-ENERGIZED connectors can be quickly and easily connected and disconnected using standard hand tools and equipment in accordance with accepted operating practices. Optional accessories allow visible external separation, by-pass, isolation, dead-ending, grounding, and testing as well as adding taps, surge arresters and circuit protection.

Hot-stick operable and separable joint systems are shown on pages 14 thru 19.

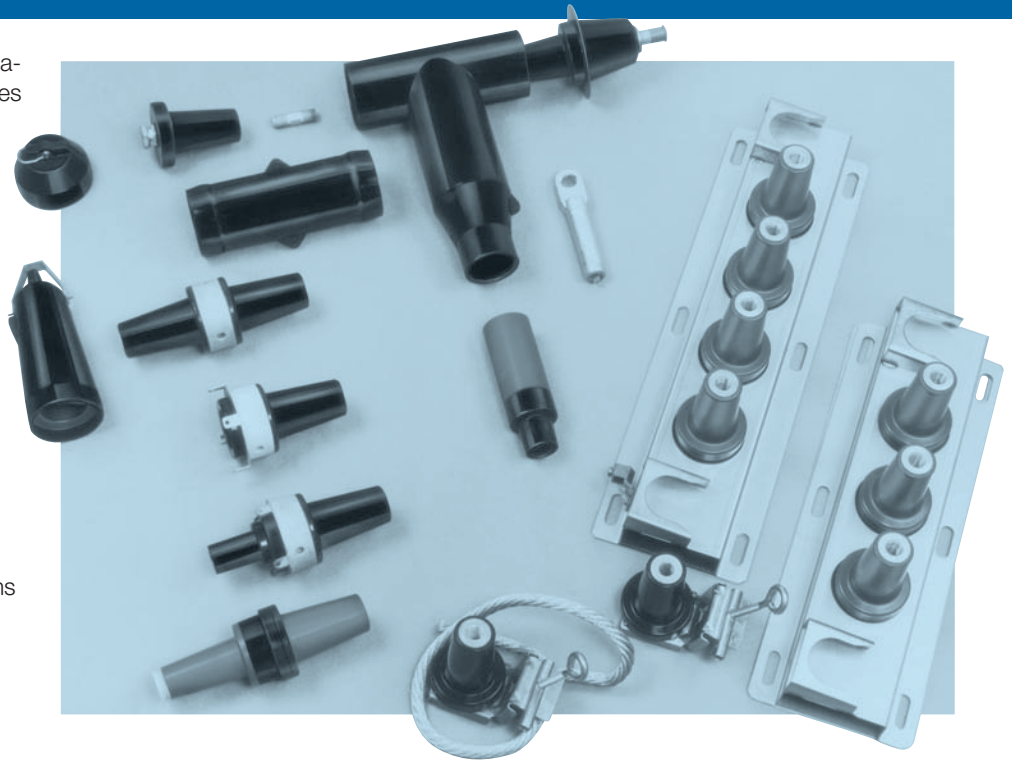

RATINGS OVERVIEW

See page 2 for complete information.

CURRENT RATINGS

(Prefixes: 650, K650, K655, K656, 750, 755, 756 & 03700)

600 Amp Continuous
25kA sym., 10 cycles

(Prefixes 675, K675, K676, 775, 776 & 03702)

900 Amp Continuous
25kA sym., 10 cycles

NOTE: 900 Amp ratings require copper cable and copper current-carrying components.

VOLTAGE RATINGS

15/25kV Class (5kV thru 28kV)

16.2kV Phase-to-Ground
28kV Phase-to-Phase
140kV BIL

45kV AC Withstand
84kV DC Withstand
21.5kV Corona Extinction

35kV Class

21.1kV Phase-to-Ground
36.6kV Phase-to-Phase
150kV BIL

50kV AC Withstand
103kV DC Withstand
26kV Corona Extinction

Note: Elastimold has increased the IEEE Standard Production and Design Test levels for 25kV Class products to include 27kV and 28kV systems.

SEPARABLE CONNECTORS 600 SERIES DEADBREAK

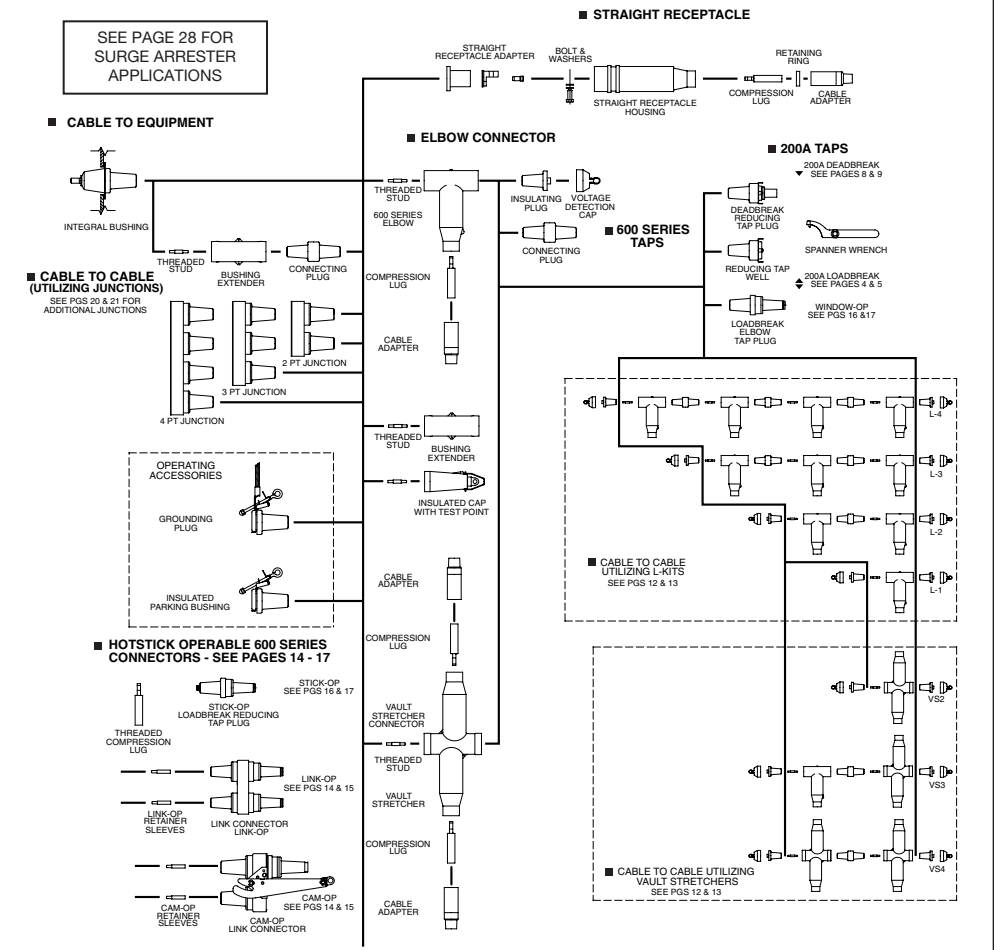

DEADFRONT LIVEFRONT	SEPARABLE CONNECTORS			PART #
	FUSED ELBOWS	200 AMP LOADBREAK	5-15kV	
	CABLE JOINTS	200 AMP DEADBREAK	25kV	
	TERMINATIONS	600 SERIES DEADBREAK	35kV	
	SURGE ARRESTERS			

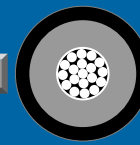

Part numbers that contain the letters **W** or **X** are size sensitive. To complete the part number, refer to the **W** or **X** tables indicated.

600 SERIES DEADBREAK

Illustration (not to scale)	Description	Voltage Class	ELASTIMOLD Part Number	Notes
	600 Series Elbow (w/ Insul. Plug, Cap, Stud, Lug & Cable Adapter)	15/25kV 35kV	K655LR-WOX Use Tables W7 and X6 755LR-WOX Use Tables W9 and X6	N1,2,13 N1,2,13
	600 Series Elbow w/ Test Point (w/ Insul. Plug, Cap, Stud, Lug & Cable Adapter)	15/25kV 35kV	K656LR-WOX Use Tables W7 and X6 756LR-WOX Use Tables W9 and X6	N1,2,13 N1,2,13
	600 Series Elbow Housing only (w/ Stud)	15/25kV 35kV	K655BLR 755BLR	N1,3 N1,3
	600 Series Elbow w/ Test Point (Housing only w/ Stud)	15/25kV 35kV	K656BLR 756BLR	N1,3 N1,3
	600 Series Straight Receptacle (w/Cable Adapter, Lug & Retaining Ring)	15/25kV	K655SR-WOX Use Tables W7 and X6	N1,2,12
	600 Series Straight Receptacle Housing (Lug & Cable Adapter not included)	15/25kV	K655BSR	N1,12
	Straight Receptacle Adapter	15/25kV	K650SRA	N1,4
	600 Series Vault Stretcher (Housing only w/ Stud)	15/25kV 35kV	K655BVS 755BVS	N1,9 N1,9
	Cable Size Adapter	15/25kV 35kV	655CA-W Use Table W7 755CA-W Use Table W9	
	Compression Lug	ALL	03700X Use Table X6 03702X Use Table X6	N5 N6
	600 Series Elbow & Vault Stretcher Size Sensitive Kit (Cable Adapter & Lug)	15/25kV 35kV	655CK-WOX Use Tables W7 and X6 755CK-WOX Use Tables W9 and X6	N2 N2
	Adapter Retaining Ring	ALL	650ARR-X Use Table X6	
	600 Series Straight Receptacle Size Sensitive Kit (Cable Adapter, Retaining Ring & Lug)	15/25kV	655CK-WOX-ARR Use Tables W7 and X6	N2
	Bushing Extender (w/ Stud)	15/25kV 35kV	K655BE 755BE	N1,3 N1,3
	Insulated Cap w/ Test Point (w/ Stud)	15/25kV	K656DR	N3,7
	Insulating Plug (w/ Cap)	15/25kV 35kV	K650BIP 750BIP	N1,7,8 N1,7,8
	Grounding Plug (Ground Lead 2/0 AWG x 30")	15/25kV 35kV	650GP 750GP	N1,7,8 N1,7,8
	Insulated Parking Bushing	15/25kV 35kV	K650SOP 750SOP	N7,8 N7,8
	Connecting Plug	15/25kV 15/25kV 35kV	K650CP K651CP 750CP	N1,7,8,9,14 N1,7,8,10 N1,7,8,10

Illustration (not to scale)	Description	Voltage Class	ELASTIMOLD Part Number	Notes
	Deadbreak Reducing Tap Plug	15/25kV	K650RTP	N1,7,8,9
	Reducing Tap Well	15/25kV	K650RTW	N1,7,8,9
	Loadbreak Elbow Tap Plug	15kV 25kV 35kV	650ETP K650ETP 750ETP	N1,7,8,10,13 N1,7,8,10,13 N1,7,8,10,13
	Vault Stretcher Threaded Stud	15/25kV 35kV	650VSA 750VSA	N1 N1
	600 Series Elbow Threaded Stud	15/25kV 35kV	650SA 750SA	N1 N1
	Assembly Tool (Window-Op)	ALL	600ATM	N13
	Spanner Wrench	ALL	600SW	N9
	2-Point Junction	15/25kV 35kV	K650J2 750J2	N1,11,15 N1,11,15
	3-Point Junction	15/25kV 35kV	K650J3 750J3	N1,11,15 N1,11,15
	4-Point Junction	15/25kV 35kV	K650J4 750J4	N1,11,15 N1,11,15

N1. For 900 Amp ratings, substitute 675 for 650 and 655; 676 for 656; K671 for K651; K675 for K650 and K655; K676 for K656; 775 for 750 and 755; 776 for 756 and 2X for OX in the part number. The 900 Amp rating requires copper current-carrying connector components and copper conductor cable.

N2. Add suffix symbol from page 31 to include cable shield grounding kit and/or cable jacket sealing kit.

N3. Available without the stud by adding "N" to the part number.

N4. Straight Receptacle Adapter is used to connect Straight Receptacles K655YBSR and K655YSR-WOX (Pg.14) to equipment bushings.

N5. Aluminum lug for use on aluminum or copper conductors. DO NOT substitute threaded 03600X lug.

N6. Copper lug for use on COPPER CONDUCTOR ONLY. DO NOT substitute threaded 03602X lug.

N7. Available with the stud factory-assembled by adding "SP" to the part number. 675ETP, K675ETP and 775ETP are available as -SP only. The stud is not field removable.

N8. Available with a loose stud by adding suffix "S" to the part number.

N9. 600SW spanner wrench is recommended for installation of K650CP connecting plug, deadbreak reducing tap plugs and reducing tap wells.

N10. Use 600ATM Assembly Tool.

N11. Rubber junction with stainless steel mounting plate and back plate. Add "-U" for rubber junction with stainless steel mounting plate, back plate and adjustable mounting bracket.

Add "-4" for rubber junction only.
Add "-5" for rubber junction, stainless steel U-straps and back plate.

N12. 600 Series Elbows and Straight Receptacles with IEEE Std. 386 capacitive test points are available by substituting 656 for 655; K656 for K655; K676 for K675; 756 for 755; 676 for 675; K676 for K675 and 776 for 775 in the part number.

N13. See page 17 for Window-Op Connector Kit.

N14. Superseded by K651CP.

N15. Two - six-position multi-point junctions shown on pages 20 and 21.

Refer to the **W** and **X** tables on pages 34 and 35 for sizing to cable insulation diameter and conductor size.

For cable shield adapters and jacket seals, see page 30.

SEPARABLE CONNECTORS 600 SERIES DEADBREAK Cont'd from Pg. 11

600 Series deadbreak elbows, straight receptacles, junctions, vault stretchers and accessories are used to connect equipment and cable on primary feeder and network circuits. Designs accommodate large conductors and feature bolted connections and deadfront modular construction for maximum reliability, performance and versatility.

DE-ENERGIZED connectors can be quickly and easily connected and disconnected using standard hand tools and equipment in accordance with accepted operating practices. Optional accessories allow visible external separation, by-pass, isolation, dead-ending, grounding, and testing as well as adding taps, surge arresters and circuit protection.

Hot-stick operable and separable joint systems are shown on pages 14 thru 19.

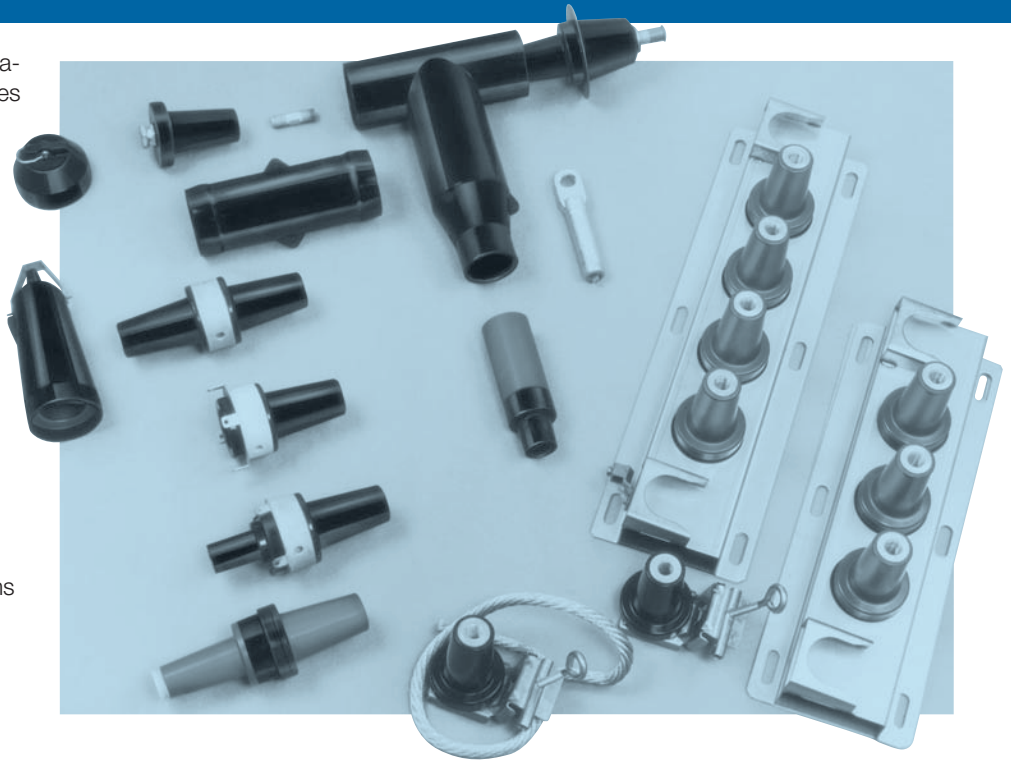

RATINGS OVERVIEW

See page 2 for complete information.

CURRENT RATINGS

(Prefixes: 650, K650, K655, K656, 750, 755, 756 & 03700)

600 Amp Continuous
25kA sym., 10 cycles

(Prefixes 675, K675, K676, 775, 776 & 03702)

900 Amp Continuous
25kA sym., 10 cycles

NOTE: 900 Amp ratings require copper cable and copper current-carrying components.

VOLTAGE RATINGS

15/25kV Class (5kV thru 28kV)

16.2kV Phase-to-Ground
28kV Phase-to-Phase
140kV BIL
45kV AC Withstand
84kV DC Withstand
21.5kV Corona Extinction

35kV Class

21.1kV Phase-to-Ground
36.6kV Phase-to-Phase
150kV BIL
50kV AC Withstand
103kV DC Withstand
26kV Corona Extinction

Note: Elastimold has increased the IEEE Standard Production and Design Test levels for 25kV Class products to include 27kV and 28kV systems.

SEPARABLE CONNECTORS 600 SERIES DEADBREAK

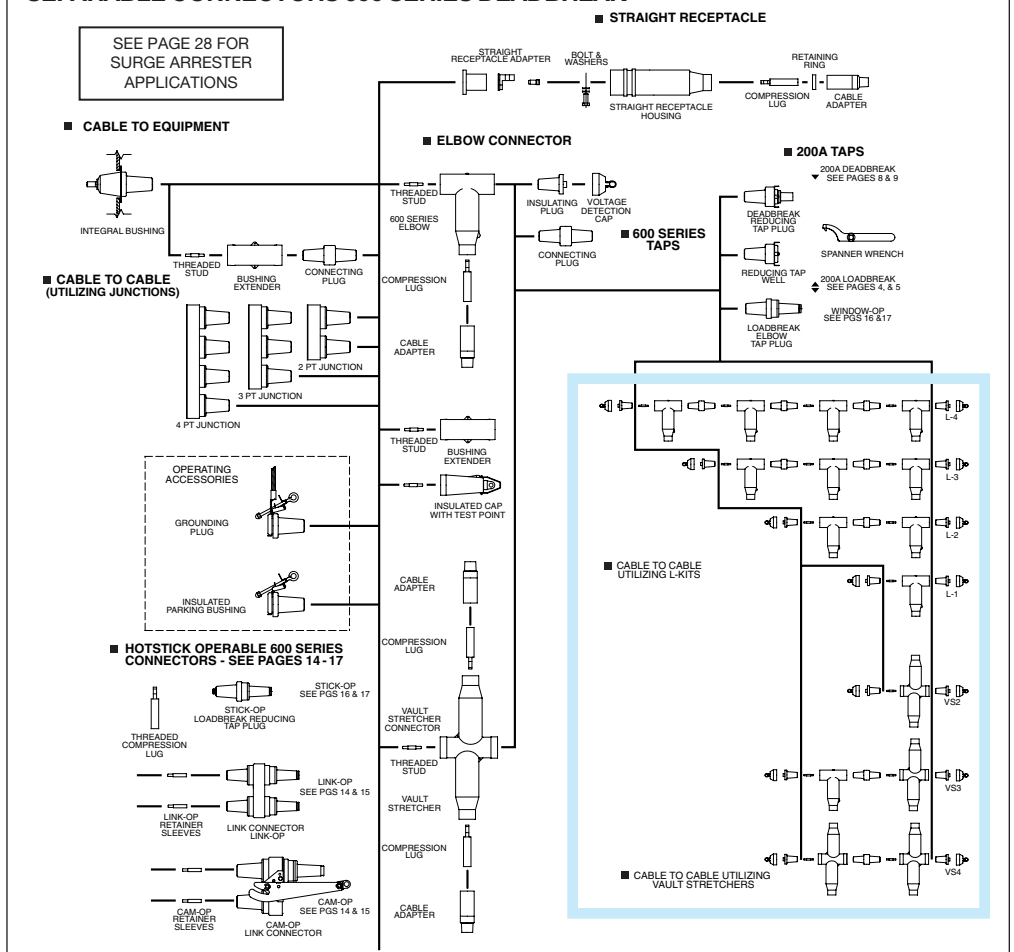

	SEPARABLE CONNECTORS		
DEADFRONT	FUSED ELBOWS	200 AMP LOADBREAK	5-15kV
LIVEFRONT	CABLE JOINTS	200 AMP DEADBREAK	25kV
	TERMINATIONS	600 SERIES DEADBREAK	35kV
	SURGE ARRESTERS		

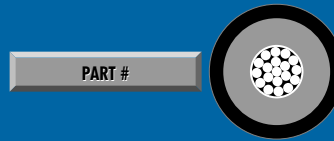

Part numbers that contain the letters **W** or **X** are size sensitive. To complete the part number, refer to the **W** or **X** tables indicated.

600 SERIES DEADBREAK

Illustration (not to scale)	Description	Voltage Class	ELASTIMOLD Part Number	Notes
	1-way L-Kit	15/25kV 35kV	K655L1 755L1	N1,2,3,4 N1,2,3,4
	2-way L-Kit	15/25kV 35kV	K655L2 755L2	N1,2,3,4, 5,6,7 N1,2,3,4 5,6,7
	2-way VS-Kit	15/25kV 35kV	K655VSL2 755VSL2	N1,2,3 N1,2,3
	3-way L-Kit	15/25kV 35kV	K655L3 755L3	N1,2,3,4,5 N1,2,3,4,5
	3-Way VS Kit	15/25kV 35kV	K655VSL3 755VSL3	N1,2,3,5,6,7 N1,2,3,5,6,7
	4-Way L-Kit	15/25kV 35kV	K655L4 755L4	N1,2,3,4,5 N1,2,3,4,5
	4-Way VS-Kit	15/25kV 35kV	K655VSL4 755VSL4	N1,2,3,5 N1,2,3,5
	Assembly Tool (Window-Op)	ALL	600ATM	N8
	Spanner Wrench	ALL	600SW	N2

- N1. For 900 Amp ratings, substitute 675 for 650 and 655; 676 for 656; K675 for K650 and K655; K676 for K656; 775 for 750 and 755; 776 for 756 and 2X for 0X in the part number. The 900 Amp rating requires copper current-carrying connector components and copper conductor cable.
- N2. 600SW spanner wrench is recommended for installation of K650CP connecting plug, deadbreak reducing tap plugs and reducing tap wells.
- N3. L-Kits and VS-Kits do not include cable adapters or compression lugs. These items must be ordered separately.
- N4. 600 Series Elbows and Straight Receptacles with IEEE Std. 386 capacitive test points are available by substituting 656 for 655; K656 for K655; K676 for K675; 756 for 755; 676 for 675; K676 for K675 and 776 for 775 in the part number.
- N5. 600ATM is recommended for installing K651CP and 750CP.
- N6. Can be used as a repair joint. (Gains 3-1/2" of repair length)
- N7. Can be used as a reducing joint for different size cables.
- N8. See page 17 for Window-Op Connector Kit.

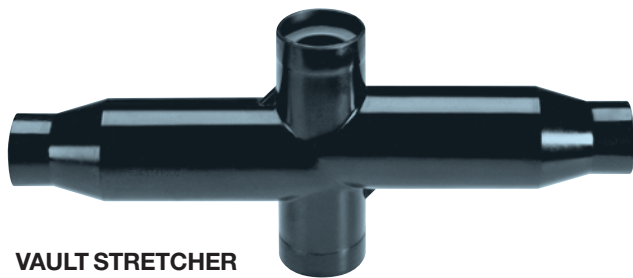

VAULT STRETCHER

Provides an alternate method of splicing and joining various types and styles of cables using standard 600 Series components.

Refer to the **W** and **X** tables on pages 34 and 35 for sizing to cable insulation diameter and conductor size.

For cable shield adapters and jacket seals, see page 30.

SEPARABLE CONNECTORS CAM-OP, LINK-OP 600 SERIES DEADBREAK

Elastimold's 600 Series Cam-Op™, and Link-Op™ deadbreak connector systems incorporate provisions for hotstick operation of DE-ENERGIZED primary feeder or network circuits. Configurations allow external visible break, testing, grounding and isolation. Retrofit kits allow upgrading existing equipment.

Cam-Op systems utilize pin and socket connectors. Link-Op connectors are bolted and installed using torque controlled tools. Either system can be retrofitted to existing equipment.

The Cam-Op and Link-Op connectors are unique, allowing all hotstick operations to be completed **without moving the cable**, an important consideration when large, stiff cables prohibit movement.

The Cam-Op connector is easily installed or removed by hotstick operation of the cam action disconnect lever.

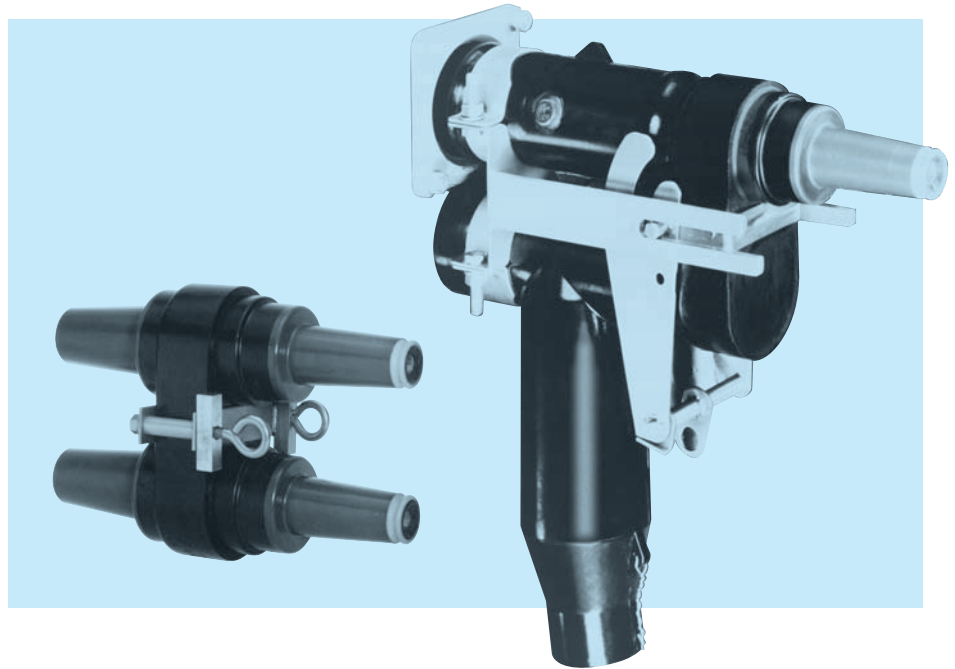

RATINGS OVERVIEW

See page 2 for complete information.

CURRENT RATINGS

600 & 900 Amp Continuous
25kA sym., 10 cycles

NOTE: 900 Amp ratings require copper cable and copper current-carrying components.

CONTINUOUS VOLTAGE RATINGS

15kV Class

8.3kV Phase-to-Ground
14.4kV Phase-to-Phase
95kV BIL
34kV AC Withstand
53kV DC Withstand
11kV Corona Extinction

25kV Class

15.2kV Phase-to-Ground
26.3kV Phase-to-Phase
125kV BIL
40kV AC Withstand
78kV DC Withstand
19kV Corona Extinction

35kV Class

21.1kV Phase-to-Ground
36.6kV Phase-to-Phase
150kV BIL
50kV AC Withstand
103kV DC Withstand
26kV Corona Extinction

CAM-OP & LINK-OP SYSTEM – 600 SERIES DEADBREAK

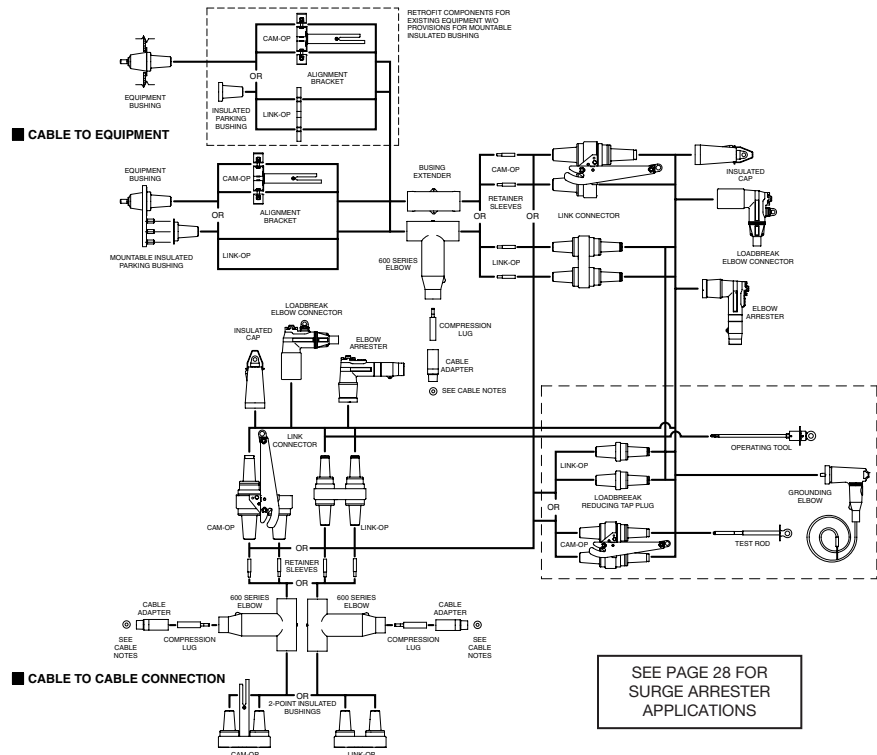

	SEPARABLE CONNECTORS		
DEADFRONT	FUSED ELBOWS	200 AMP LOADBREAK	5-15kV
LIVEFRONT	CABLE JOINTS	200 AMP DEADBREAK	25kV
	TERMINATIONS	600 SERIES DEADBREAK	35kV
	SURGE ARRESTERS		

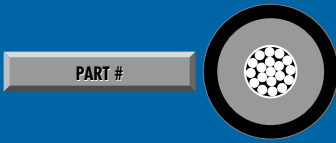

Part numbers that contain the letters **W** or **X** are size sensitive. To complete the part number, refer to the **W** or **X** tables indicated.

CAM-OP™ & LINK-OP™

Illustration (not to scale)	Description	Voltage Class	ELASTIMOLD Part Number	Notes
	CAM-OP CONNECTOR KIT	15kV 25kV 35kV	655LINK-C-LR-WOX-B-DRG Use Tables W7 and X6 K655LINK-C-LR-WOX-B-DRG Use Tables W7 and X6 755LINK-C-LR-WOX-B-DRG Use Tables W9 and X6	N1,3,11, 13,14,18 N1,3,11, 13,14,18 N1,3,11, 13,14,18
	LINK-OP CONNECTOR KIT	15kV 25kV 35kV	655LINK-B-LR-WOX-B-DRG Use Tables W7 and X6 K655LINK-B-LR-WOX-B-DRG Use Tables W7 and X6 755LINK-B-LR-WOX-B-DRG Use Tables W9 and X6	N2,3,11,12 13,14,18 N2,3,11, 13,14,18 N2,3,11, 13,14,18
	Mountable Insulated Bushing	25kV 35kV	K650LBM-3 750LBM-3	N3 N3
	RETROFIT CAM-OP CONNECTOR KIT	15kV 25kV 35kV	655LINK-C-LR-WOX-A-DRG Use Tables W7 and X6 K655LINK-C-LR-WOX-A-DRG Use Tables W7 and X6 755LINK-C-LR-WOX-A-DRG Use Tables W9 and X6	N5,11,13 14,18 N5,11,13 14,18 N5,11,13 14,18
	RETROFIT LINK-OP CONNECTOR KIT	15kV 25kV 35kV	655LINK-B-LR-WOX-A-DRG Use Tables W7 and X6 K655LINK-B-LR-WOX-A-DRG Use Tables W7 and X6 755LINK-B-LR-WOX-A-DRG Use Tables W9 and X6	N6,11,12, 13,14,18 N6,11,12, 13,14,18 N6,11,12, 13,14,18
	Insulating Plug	25kV 35kV	K650LB 750LB	N4 N4
	CAM-OP Alignment Bracket	15kV 25kV 35kV	650CAB K650CAB 750CAB	
	LINK-OP Alignment Bracket (Retrofit LINK-OP Only)	ALL ALL	650AB 650ABV	N15 N15
	Compression Lug	ALL ALL	03700X Use Table X6 03702X Use Table X6	N7 N8
	CAM-OP & LINK-OP Size Sensitive Kit (Cable Adapter & Lug)	15/25kV 35kV	655CK-WOX Use Tables W7 and X6 755CK-WOX Use Tables W9 and X6	N13 N13
	CAM-OP Retaining Sleeve	ALL	650RSC	N11
	LINK-OP Retaining Sleeve	ALL	650RS	N11
	CAM-OP CABLE JOINT KIT	15kV 25kV 35kV	655BI-LINK-C-LR-WOX-DRG Use Tables W7 and X6 K655BI-LINK-C-LR-WOX-DRG Use Tables W7 and X6 755BI-LINK-C-LR-WOX-DRG Use Tables W9 and X6	N9,11,13 14,18 N9,11,13 14,18 N9,11,13 14,18
	LINK-OP CABLE JOINT KIT	15kV 25kV 35kV	655BI-LINK-B-LR-WOX-DRG Use Tables W7 and X6 K655BI-LINK-B-LR-WOX-DRG Use Tables W7 and X6 755BI-LINK-B-LR-WOX-DRG Use Tables W9 and X6	N10,11,12, 13,14,18 N10,11,12, 13,14,18 N10,11,12, 13,14,18
	CAM-OP Loadbreak Reducing Tap Plugs (Visi-Break)	15kV 25kV 35kV	650LK-C-VB K650LK-C-VB 750LK-C-VB	
	LINK-OP Loadbreak Reducing Tap Plug	15kV 25kV 35kV	650LT-B K650LT-B 750LT-B	N11

Illustration (not to scale)	Description	Voltage Class	ELASTIMOLD Part Number	Notes
	Grounding Elbow (1/0 AWG x 6' Ground Lead)	15kV 25kV 35kV	160GLR 370GLR 370GLR	N19 N19
	Test Rod	ALL	370TR	
	Assembly Tool	ALL	600AT	N11
	CAM-OP OPERATING KIT	15kV 25kV 35kV	650CAM-OK K650CAM-OK 750CAM-OK	N16 N16 N16
	LINK-OP OPERATING KIT	15kV 25kV 35kV	650LINK-OK K650LINK-OK 750LINK-OK	N17 N17 N17

- N1. Cam-Op connector kit includes: 1- Cam-Op link; 1- elbow housing; 1- cable adapter; 1-0370 style lug; 1- bushing extender; 2- retainer sleeves; 1- insulated cap; 1- mountable insulated bushing and 1- alignment bracket.
- N2. Link-Op connector kit includes: 1- Link-Op link; 1- elbow housing; 1- cable adapter; 1-0370 style lug; 1- bushing extender; 2- retainer sleeves; 2- insulated caps; and 1- mountable insulated bushing.
- N3. Mountable insulated bushing included with Cam-Op and Link-Op connector kit. Requires 3 threaded studs on equipment faceplate for installation.
- N4. Use with the Retrofit Cam-Op and Retrofit Link-Op connector kit.
- N5. Retrofit Cam-Op connector kit includes: 1- link; 1- elbow housing; 1- cable adapter; 1-0370 style lug; 1- bushing extender; 2- retainer sleeves; 1- insulated cap; 1- insulating plug; and 1- alignment bracket.
- N6. Retrofit Link-Op connector kit includes: 1- link; 1- elbow housing; 1- cable adapter; 1-0370 style lug; 1- bushing extender; 2- retainer sleeves; 2- insulated caps; 1- insulating plug; and 1- alignment bracket.
- N7. Aluminum lug for use on aluminum or copper conductors. DO NOT substitute threaded 03600X lug.
- N8. Copper lug for use on COPPER CONDUCTOR ONLY. DO NOT substitute 03602X threaded lug.
- N9. Cam-Op Cable Joint Kit includes: 1- Cam-Op link; 1- Cam-Op BI-SOP; 2- elbow housings; 2- cable adapters; 2- 0370 style lugs; 2- retainer sleeves; 1- insulated cap.
- N10. Link-Op Cable Joint Kit includes: 1- Link-Op link; 1- Link-Op BI-SOP; 2- elbow housings; 2- cable adapters; 2- 0370 style lugs; 2- retainer sleeves; 2- insulated caps.
- N11. 600AT assembly tool required for operation and/or installation of Link-Op. 600ATM is recommended for installing Link-Op/Cam-Op retaining sleeves.
- N12. For 900 Amp ratings, substitute 675 for 650 and 655; 676 for 656; K675 for K650 and K655; K676 for K656; 775 for 750 and 755; 776 for 756 and 2X for 0X in the part number. The 900 Amp rating requires copper current-carrying connector components and copper conductor cable.
- N13. Add suffix symbol from page 31 to include cable shield grounding kit and/or cable jacket sealing kit.
- N14. To add elbows or arresters instead of insulating caps, replace the "DRG" with "LR-WX" for elbows (with test point) or "ESA" for elbow arresters.
- N15. The 650ABV is required when the bushing horizontal spacing on the equipment or junctions is less than 5".
- N16. Cam-Op operating kit includes accessories that enable visible break, testing, isolation and grounding functions to be performed. Kit includes: 3- Cam-Op loadbreak reducing tap plugs; 3- grounding elbows; 1- assembly tool; 1- test rod; 1- carry case; 1- lubricant; 1- instructions.
- N17. Link-Op operating kit includes accessories that enable visible break, testing, isolation and grounding functions to be performed. Kit includes: 6- Link-Op loadbreak reducing tap plugs; 3- grounding elbows; 1- assembly tool; 1- test rod; 1- carry case; 1- lubricant; 1- instructions.
- N18. 600 Series Elbows and Straight Receptacles with IEEE Std. 386 capacitive test points are available by substituting 656 for 655; K656 for K655; K676 for K675; 756 for 755; 676 for 675; K676 for K675 and 776 for 775 in the part number.
- N19. Rated for both 25kV and 35kV applications.

Refer to the **W** and **X** tables on pages 34 and 35 for sizing to cable insulation diameter and conductor size.
For cable shield adapters and jacket seals, see page 30.

SEPARABLE CONNECTORS STICK-OP, WINDOW-OP 600 SERIES DEADBREAK

Elastimold's 600 Series Window-Op™ and Stick-Op™ deadbreak connector systems incorporate provisions for hotstick operation of DE-ENERGIZED primary feeder or network circuits.

The Window-Op and Stick-Op connectors allow direct testing and grounding with no required cable movement.

Window-Op is ideal for equipment applications which include viewing windows to provide an internal visible break that does not require hot stick removal of the elbows.

Stick-Op provides an external visible break by hot stick removal of the elbow.

Window-Op and Stick-Op connectors are bolted and installed using torque controlled tools.

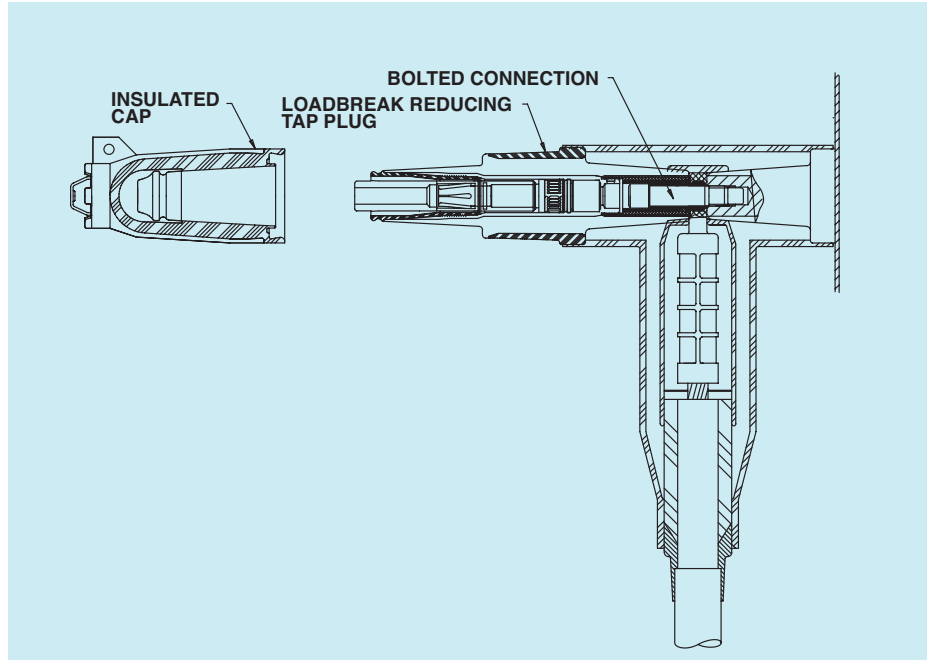

RATINGS OVERVIEW

See page 2 for complete information.

CURRENT RATINGS

600 & 900 Amp Continuous
25kA sym., 10 cycles

NOTE: 900 Amp ratings require copper cable and copper current-carrying components.

CONTINUOUS VOLTAGE RATINGS

15kV Class
8.3kV Phase-to-Ground
14.4kV Phase-to-Phase
95kV BIL
34kV AC Withstand
53kV DC Withstand
11kV Corona Extinction

25kV Class
15.2kV Phase-to-Ground
26.3kV Phase-to-Phase
125kV BIL
40kV AC Withstand
78kV DC Withstand
19kV Corona Extinction

35kV Class
21.1kV Phase-to-Ground
36.6kV Phase-to-Phase
150kV BIL
50kV AC Withstand
103kV DC Withstand
26kV Corona Extinction

STICK-OP & WINDOW-OP SYSTEM – 600 SERIES DEADBREAK

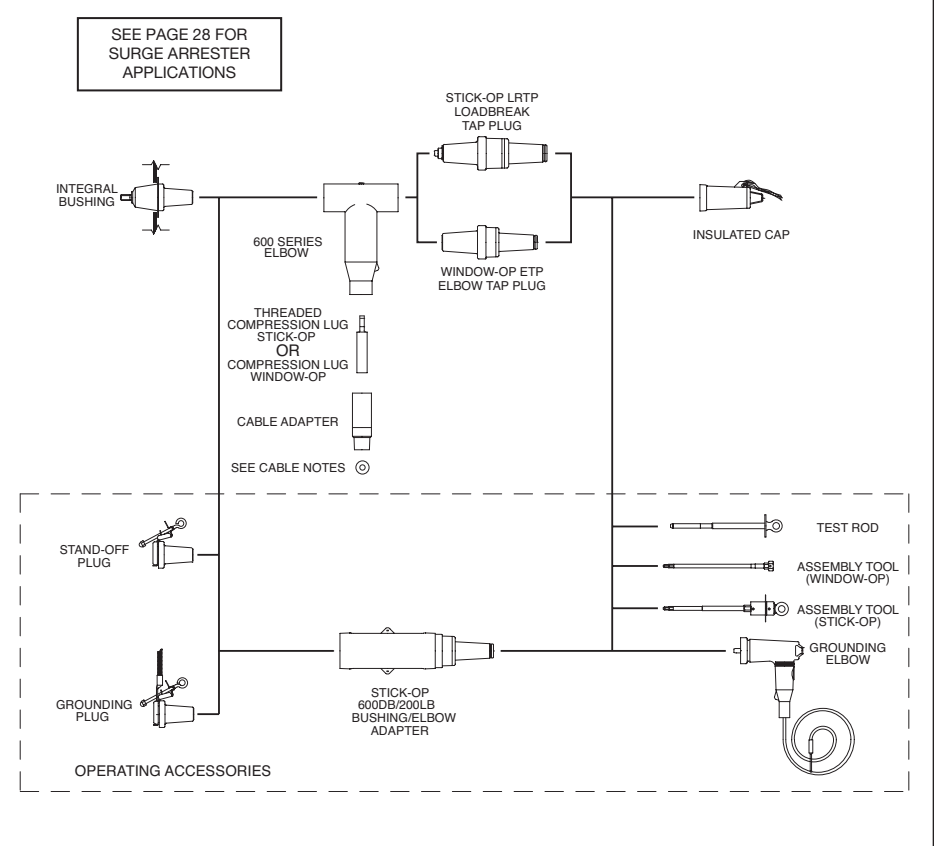

SEPARABLE CONNECTORS		200 AMP LOADBREAK	5-15kV
DEADFRONT	FUSED ELBOWS	200 AMP DEADBREAK	25kV
LIVEFRONT	CABLE JOINTS	600 SERIES DEADBREAK	35kV
	TERMINATIONS		
	SURGE ARRESTERS		

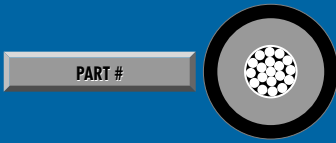

Part numbers that contain the letters **W** or **X** are size sensitive. To complete the part number, refer to the **W** or **X** tables indicated.

STICK-OP™ & WINDOW-OP™

Illustration (not to scale)	Description	Voltage Class	ELASTIMOLD Part Number	Notes
	WINDOW-OP CONNECTOR KIT	15kV 25kV 35kV	655ETP-W0X-DRG Use Tables W7 and X6 K655ETP-W0X-DRG Use Tables W7 and X6 755ETP-W0X-DRG Use Tables W9 and X6	N1,4,5,6 13,15
	STICK-OP CONNECTOR KIT	15kV 25kV 35kV	655LRTP-W0X-DRG Use Tables W7 and X6 K655LRTP-W0X-DRG Use Tables W7 and X6 755LRTP-W0X-DRG Use Tables W9 and X6	N2,3,4,5, 8,13
	WINDOW-OP Loadbreak Elbow Tap Plug	15kV 25kV 35kV	650ETP K650ETP 750ETP	N4,15 N4,15 N4,15
	STICK-OP Loadbreak Reducing Tap Plug	15kV 25kV 35kV	650LRTPA3 K650LRTPA2 750LRTPA2	N3,4
	STICK-OP Bushing Adapter	15kV 25kV 35kV	650BEA3 K650BEA2 750BEA2	N3,4
	Compression Lug WINDOW-OP	ALL	03700X Use Tables X6	N6
	Threaded Compression Lug STICK-OP	ALL	03600X Use Tables X6	N8
	WINDOW-OP Size Sensitive Kit (Cable Adapter & Lug)	15/25kV 35kV	655CK-W0X Use Tables W7 and X6 755CK-W0X Use Tables W9 and X6	N5 N5
	STICK-OP Size Sensitive Kit (Cable Adapter & Threaded Lug)	15/25kV 35kV	655TCK-W0X Use Tables W7 and X6 755TCK-W0X Use Tables W9 and X6	N5 N5
	Extraction Tool	ALL	650ET	N10
	Grounding Elbow (1/0 AWG x 6' Ground Lead)	15kV 25kV 35kV	160GLR 370GLR 370GLR	N14 N14
	Test Rod	ALL	370TR	
	Assembly Tool (Stick-Op)	ALL	600AT	N3
	Assembly Tool (Window-Op)	ALL	600ATM	N15
	STICK-OP OPERATING KIT	15kV 25kV 35kV	650STICK-OK K650STICK-OK 750STICK-OK	N11 N11 N11
	WINDOW-OP OPERATING KIT	15kV 25kV 35kV	650WINDOW-OK K650WINDOW-OK 750WINDOW-OK	N12 N12 N12

- N1. Window-Op Kit includes: insulated cap; Window-Op reducing tap plug; 600 Series elbow housing; cable adapter; and 0370 style compression lug.
- N2. Stick-Op Kit includes insulated cap; Stick-Op Loadbreak reducing tap plug; 600A Elbow Housing; cable adapter; and threaded 0360 style compression lug.
- N3. 600AT assembly tool required for operation and/or installation of Stick-Op.
- N4. For 900 Amp ratings, substitute 675 for 650 and 655; 676 for 656; K675 for K650 and K655; K676 for K656; 775 for 750 and 755; 776 for 756 and 2X for 0X in the part number. The 900 Amp rating requires copper current-carrying connector components and copper conductor cable.
- N5. Add suffix symbol from page 31 to include cable shield grounding kit and/or cable jacket sealing kit.
- N6. Aluminum lug for use on aluminum or copper conductors. DO NOT substitute threaded 03600X lug.
- N7. Copper lug for use on COPPER CONDUCTOR ONLY. DO NOT substitute 03602X threaded lug.
- N8. Threaded aluminum lug (Stick-Op only) for use on copper or aluminum conductors. DO NOT substitute unthreaded 03700X lugs. DO NOT use with 675, 676, K675, K676, 775 or 776 part numbers.
- N9. Threaded copper lug (Stick-Op only) for use on copper conductors only. DO NOT substitute unthreaded 03702X lugs.
- N10. Required to disassemble Stick-Op loadbreak reducing tap plug from the threaded compression lug and 600 Series elbow after the shear-pin is broken during assembly.
- N11. Stick-Op Operating Kit includes accessories that enable visible break direct testing, isolation, and grounding functions to be performed. Kit includes: 3-insulated parking bushings; 3-grounding elbows; 3-600DB/200LB bushing/elbow adapters; 1-assembly tool; 1-test rod; 1-carry case; 1-lubricant; 1-instructions.
- N12. Window-Op Operating Kit includes accessories that enable visible grounding and direct testing functions to be performed. Kit includes: 3-grounding elbows; 1-test rod; 1-carry case; 1-lubricant; 1-instructions.
- N13. 600 Series Elbows and Straight Receptacles with IEEE Std. 386 capacitive test points are available by substituting 656 for 655; K656 for K655; K676 for K675; 756 for 755; 676 for 675; K676 for K675 and 776 for 775 in the part number.
- N14. Rated for both 25kV and 35kV applications.
- N15. 600ATM assembly tool required for Window-Op assembly. 50 – 60 ft/lbs torque wrench required but not included.

Refer to the **W** and **X** tables on pages 34 and 35 for sizing to cable insulation diameter and conductor size.
For cable shield adapters and jacket seals, see page 30.

SEPARABLE CONNECTORS CABLE JOINTS

600 SERIES DEADBREAK

600 Series Separable Cable Joints are available in 2, 3 and 4-way versions and include a capacitive test point as standard. Units are interchangeable, featuring bolted connections. Designs are compact and ideally suited for small vaults and manholes.

DE-ENERGIZED joints can be quickly and easily connected and disconnected using standard hand tools and equipment in accordance with accepted operating practices. Bus bars can be changed to add or remove cables from the joint.

Optional accessories include insulating and grounding caps and plugs which allow visible external separation, by-pass, isolation, dead-ending, grounding and testing.

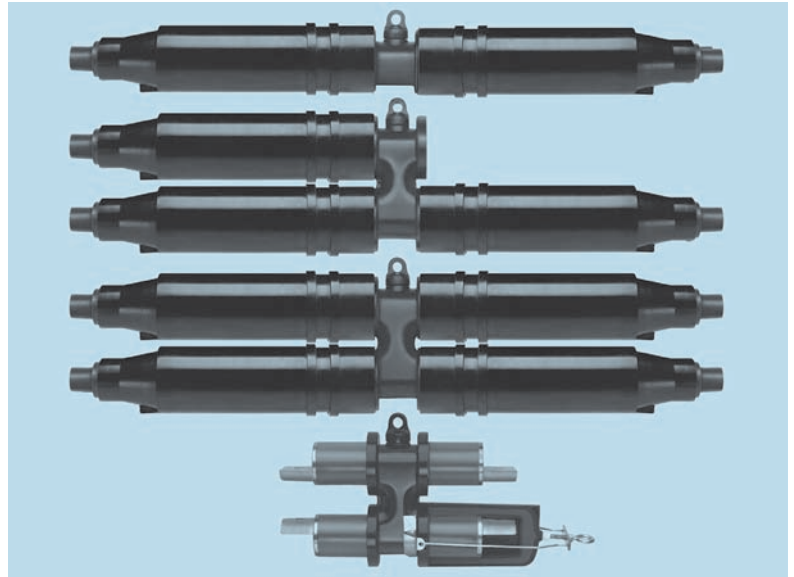

RATINGS OVERVIEW

See page 2 for complete information

CURRENT RATINGS

(Prefixes: 650, K650, K655, K656 & 03700)

600 Amp Continuous
25kA sym., 10 cycles

VOLTAGE RATINGS

15/25kV Class (5kV thru 28kV)

16.2kV Phase-to-Ground
28kV Phase-to-Phase
140kV BIL
45kV AC Withstand
84kV DC Withstand
21.5kV Corona Extinction

Note: Elastimold has increased the IEEE Standard Production and Design Test levels for 25kV Class products to include 27kV and 28kV systems.

SEPARABLE CABLE JOINTS – 600 SERIES DEADBREAK

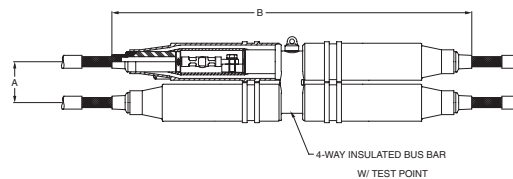

SEPARABLE
H-JOINT
(4-WAY)

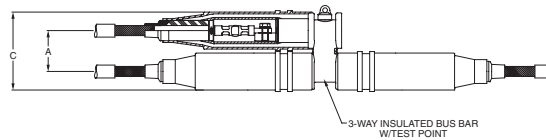

SEPARABLE
WYE-JOINT
(3-WAY)

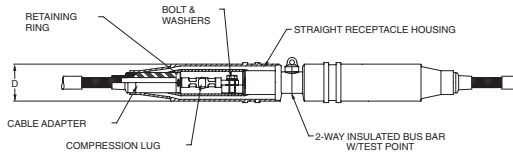

SEPARABLE
STRAIGHT JOINT
(2-WAY)

OPERATING ACCESSORIES

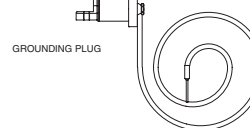
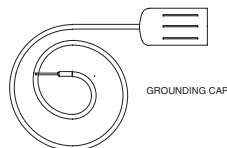
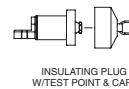
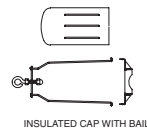

Note: The separable cable joints shown here use a special “Y” interface that may not be interchangeable with other 600 Series interfaces.

DIMENSION	INCHES
A	4 1/4
B	37 1/8
C	8 1/8
D	3 7/8

SEPARABLE CONNECTORS

DEADFRONT

LIVEFRONT

FUSED ELBOWS

CABLE JOINTS

TERMINATIONS

SURGE ARRESTERS

200 AMP LOADBREAK

200 AMP DEADBREAK

600 SERIES DEADBREAK

5-15kV

25kV

35kV

PART #

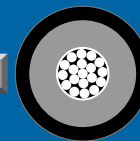

Part numbers that contain the letters **W** or **X** are size sensitive. To complete the part number, refer to the **W** or **X** tables indicated.

600 SERIES DEADBREAK

Illustration (not to scale)	Description	Voltage Class	ELASTIMOLD Part Number	Notes
	Separable Straight Joint Pkg. (2-way) w/ Test Point	15/25kV	K6561-W0X Use Tables W7 and X6	N1,8
	Basic Housing Pkg. Straight Joint w/ Test Point	15/25kV	K6561-HP	N2
	Separable Wye Joint Pkg. (3-Way) w/ Test Point	15/25kV	K656CY-W0X Use Tables W7 and X6	N1,8
	Basic Housing Pkg. Wye Joint w/ Test point	15/25kV	K656CY-HP	N2
	Separable "H" Joint Pkg. (4-Way) w/ Test Point	15/25kV	K656CH-W0X Use Tables W7 and X6	N1,8
	Basic Housing Pkg. "H" Joint w/ Test Point	15/25kV	K656CH-HP	N2
	2-Way Insulated Bus Bar w/Test Point	15/25kV	K6561-BUS	N3
	3-Way Insulated Bus Bar w/Test Point	15/25kV	K656CY-BUS	N3
	4-Way Insulated Bus Bar w/Test Point	15/25kV	K656CH-BUS	N3
	Straight Receptacle	15/25kV	K655YSR-W0X Use Tables W7 and X6	N4,8
	Straight Receptacle Housing Only	15/25kV	K655YBSR	N5, 10
	Insulated Cap w/ Bail	15/25kV	K655YDR	
	Bail Only	15/25kV	650BA	
	Cable Adapter	15/25kV	655CA-W Use Table W7	
	Adapter Retaining Ring	15/25kV	650ARR-X Use Table X6	
	Compression Lug	15/25kV 15/25kV	03700X 03702X Use Table X6	N7 N9
	600 Series Straight Receptacle Size Sensitive Kit (Cable Adapter, Retaining Ring & Lug)	15/25kV	655CK-W0X-ARR Use Tables W7 and X6	N8

Illustration (not to scale)	Description	Voltage Class	ELASTIMOLD Part Number	Notes
	Insulating Plug w/ Test Point & Cap	15/25kV	K650YBIP	
	Grounding Plug (4/0 AWG x 6' Ground Lead)	15/25kV	650YGP	
	Grounding Cap (4/0 AWG x 6' Ground Lead)	15/25kV	650GYDR	
	Stainless Steel Bolt & Washers	15/25kV	650BAW	
	Assembly/ Disassembly Tool	ALL	600YADT	N6
	Assembly/ Disassembly Tool	ALL	600RRT	N6

- N1. Complete Joint Packages consisting of: insulated bus bar; straight receptacle housings, retaining rings, cable size adapters, lugs, bolts and washers.
- N2. Housing Packages consisting of the following non-size sensitive components of the joint: insulated bus bar, straight receptacle housings, bolts and washers.
- N3. Insulated bus bar only.
- N4. Straight Receptacle consisting of: straight receptacle housing, retaining ring, cable adapter, lug, bolt and washers.
- N5. Straight receptacle housing consisting of: straight receptacle housing, bolt and washers.
- N6. Recommended for ease of assembly/disassembly of receptacles to Bus. 600 YADT is lever drive & 600RRT is screw drive.
- N7. Aluminum lug for use on aluminum or copper conductors. DO NOT substitute threaded 03600X lug.
- N8. Add suffix symbol from page 31 to include cable shield grounding kit and/or cable jacket sealing kit.
- N9. Copper lug for use with COPPER CONDUCTOR ONLY. DO NOT substitute threaded 03602X lug.
- N10. Available without the bolt & washers by adding "N" to the part number.

Refer to the **W** and **X** tables on pages 34 and 35 for sizing to cable insulation diameter and conductor size.
For cable shield adapters and jacket seals, see page 30.

MOLDED MULTI-POINT JUNCTIONS

Elastimold multi-point junctions are available in 2, 3, 4, 5 or 6 point configurations with 15, 25 or 35kV ratings. Units feature modular design flexibility, allowing selection of any combination of 200 Amp deepwell or 600 Amp bushing interfaces located on standard 4" or optional 6 1/2" centers. The 6-1/2" center spacing is especially well suited for Distributed Switchgear applications including fused elbow, MVI fault interrupter, MVS switch, junctions, etc.

Designs incorporate lightweight, damage resistant, EPDM molded rubber construction and corrosion resistant 304 stainless steel mounting brackets. Junctions are maintenance-free, fully shielded, deadfront and submersible. Units are ideally suited for subsurface, padmount, indoor and outdoor vault applications.

Elastimold multi-point junctions provide a convenient method for connecting, looping and tapping of 200 and 600 Amp elbows and other accessories at a common location where utilization of space, cable training, flexibility and operability are important.

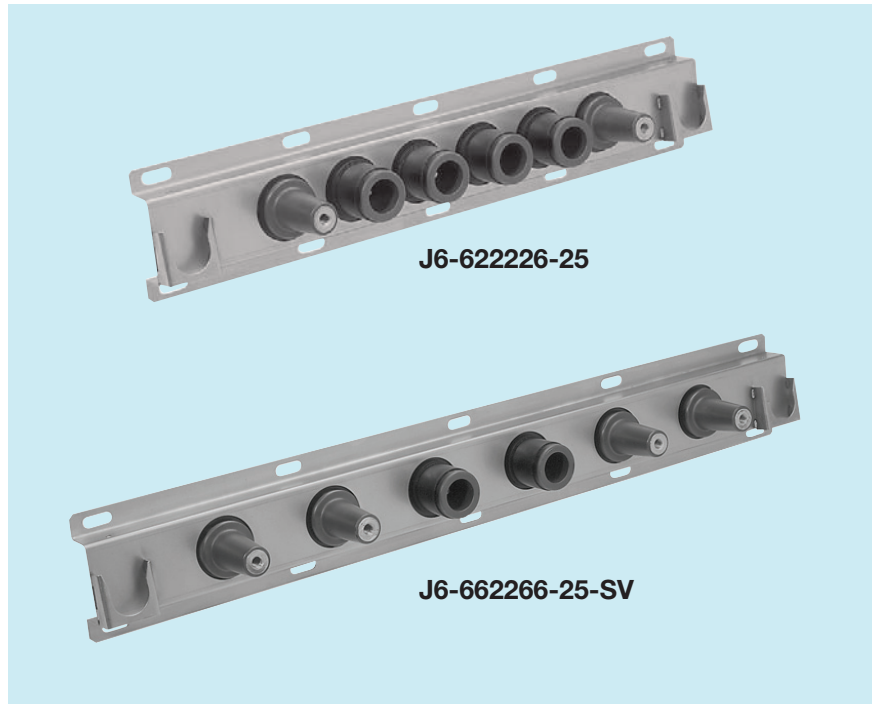

RATINGS OVERVIEW

See page 2 for complete information

CURRENT RATINGS

600 Amp Continuous
25kA sym., 10 cycles

or with 200 Amp Bushing Well versions

200 Amp Continuous
10kA sym., 10 cycles

VOLTAGE RATINGS

15kV Class

8.3kV Phase-to-Ground
95kV BIL
34kV AC Withstand
53kV DC Withstand
11kV Corona Extinction

25kV Class

16.2kV Phase-to-Ground
140kV BIL
45kV AC Withstand
84kV DC Withstand
21.5kV Corona Extinction

35kV Class

21.1kV Phase-to-Ground
150kV BIL
50kV AC Withstand
103kV DC Withstand
26kV Corona Extinction

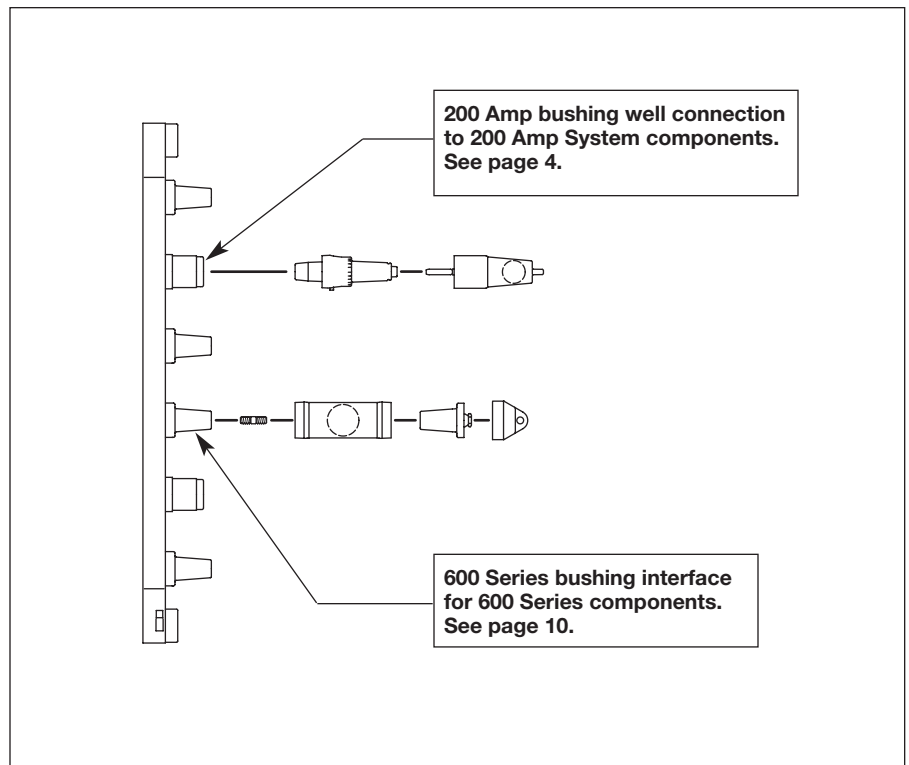

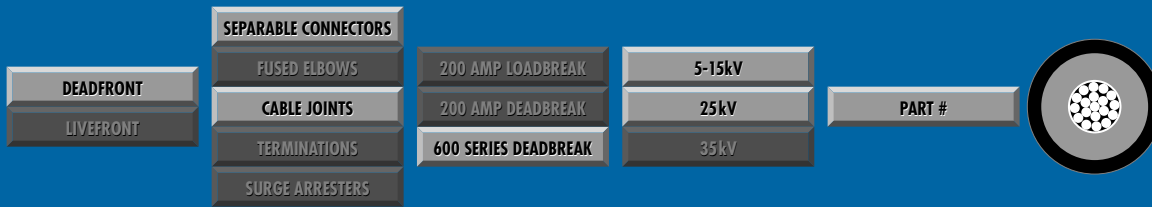

Part numbers that contain the letters **W** or **X** are size sensitive. To complete the part number, refer to the **W** or **X** tables indicated.

The Elastimold multi-point junctions feature modular design flexibility that permits the specifier to determine the positions of the bushing interfaces and bushing well positions.

Use table 1 below to construct the part number for a specific configuration.

Use table 2 to select options as required.

Note: Options are ordered and sold as separate items.

The following part number examples represent only a few of the configuration options available.

Illustration (not to scale)	Description	Voltage Class	ELASTIMOLD Part Number	Notes
	4-point Junction with two 600 Series Bushing Interfaces and two 200 Amp Wells (Std Spacing. See P/N for positioning.)	15kV	J4-6226-15	N1, 2
	6-point Junction with four 600 Series Bushing Interfaces and two 200 Amp Wells (Wide spacing. See P/N for positioning.)	25kV	J6-626626-25-SV	N1, 2
	3-point Junction with two 200 Amp Wells and one 600 Series Interface (Wide spacing. See P/N for positioning.)	35kV	J3-226-35-SV	N1, 2
	4-point Junction base with one 200 Amp Well, one Blank position and two 600 Series Bushing Interfaces (Wide spacing. See P/N for positioning.)	35kV	J4-6B26-35-SV	N1, 2

ORDERING INFORMATION

To specify and order Elastimold Multi-Point Junctions:

- Use Table 1 to construct a catalog number describing the required junction.
- Use Table 2 to select options as required. Note: Options are ordered and sold as separate items.

Table 1. Catalog Number Construction

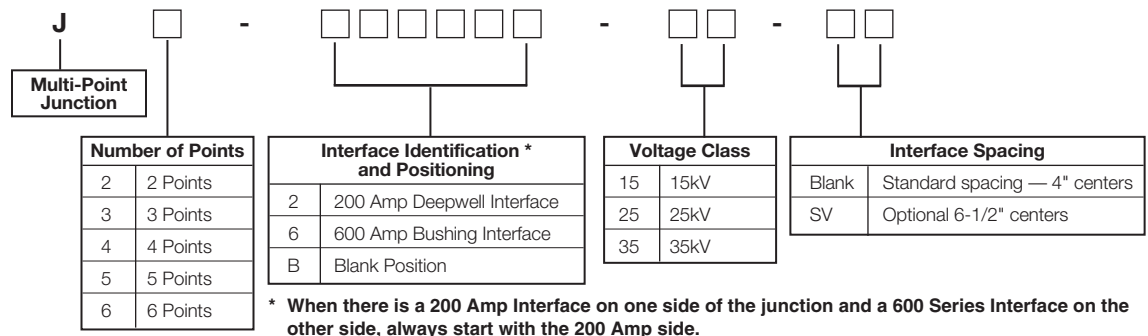

Table 2. Options

Option Catalog No.	Description
TMA	Tilt Mounting Adapter. Bolts to the bottom of the standard mounting bracket to provide 15, 30, 45 or 60 degree adjustable angle mounting. (A minimum of two Tilt Mounting Adapters are required for each installation.)

Ordering Example A

To order a 4-point, 15kV junction with 4" spacings and 600 series interfaces on the outside ways and 200 Amp wells on the inside ways specify: Catalog Number J4-6226-15.

Ordering Example B

To order a 6-point, 25kV junction with 6-1/2" spacings and 600 series interfaces on the ways 1, 3, 4, 6 and 200 Amp wells on the ways 2 and 5 specify: Catalog Number J6-626626-25-SV.

N1. The 6-1/2" wide spacing is necessary if the junction is to be used to connect with a single phase MVS Molded Vacuum Switch or MVI Molded Vacuum Interrupter.

N2. Also available with a shorter bracket without parking stands. Consult factory for special orders.

PCJ CABLE JOINTS

PCJ™ Power Cable Joints utilize permanently crimped connectors. PCJ Housings are fully insulated, shielded and sealed for direct buried, vault, submersible and other severe service applications. Units have been designed and tested per IEEE Standard 404 to assure system matched performance and ratings equal to the cable to which the splice will be installed.

PCJ Power Cable Joints are available in 2 styles:

Style 1 uses a single piece housing that is sized to accommodate a specific range of cable. Style 1 units are ideally suited for straight splicing of the same or similar cable.

Style 2 designs incorporate a universal housing with separate cable adapters to allow transition splices of different types and sizes of cable.

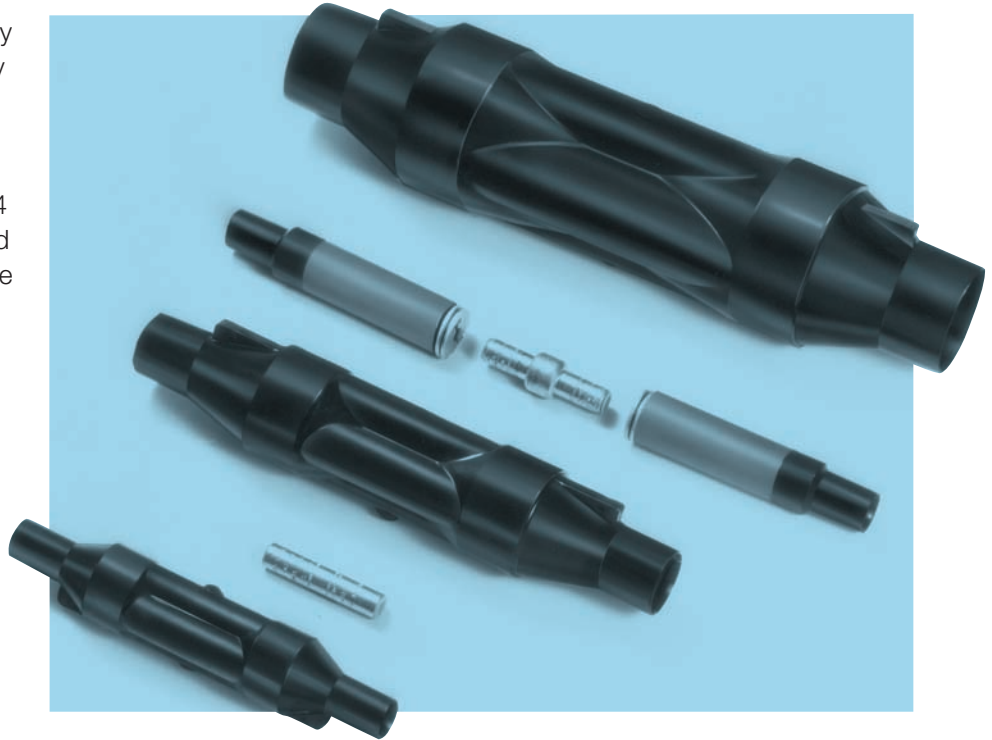

ELECTRICAL RATINGS SUMMARY

The following ratings summary is based on **IEEE Std. 404** and applies to all Elastimold PCJ Power Cable Joints.

VOLTAGE

- A.** 15kV Class (8.7kV Phase-to-Ground)
- B.** 25kV Class (14.4kV Phase-to-Ground)
- C.** 35kV Class (20.2kV Phase-to-Ground)

- **Impulse Withstand:** A=110kV, B=150kV, C=200kV BIL, 1.2 x 50 microsecond wave.
- **Corona Extinction Voltage:** A=13kV, B=22kV, C=30kV minimum, 3pC sensitivity.
- **DC Withstand:** During installation: A=56kV, B=80kV, C=100kV
- **DC Withstand:**
After installation and in service for the first 5 years:
A=18kV, B=25kV, C=31kV for XLPE Insulated Cables
and A=45kV, B=64kV, C=80kV for EPR Insulated Cables.
(Reference AEIC CS6 and CS8, Section L.2.)

CURRENT

- Continuous rating equal to the rating of the cable.
- Short-Time rating equal to the rating of the cable up to 35kA.

SHIELD DESIGN

- Meets IEEE standard 592 for Exposed Semiconducting Shields on Premolded High Voltage Cable Joints and Separable Insulated Connectors.

Production tests include 100% tests of the premolded joints to assure:

- **Corona Extinction Voltage:** A=13kV, B=22kV, C=30kV minimum, 3pC sensitivity.
- **AC Withstand:** A=35kV, B=52kV, C=69kV, 60 Hz, 1 minute.

Design tests on production joints demonstrate compliance with IEEE 404 including:

- **Corona Extinction Voltage:** A=13.0kV, B=22.0kV, C=30.0kV minimum, 3pC sensitivity.
- **AC Withstand:** A=35kV, B=52kV, C=69kV, 60 Hz 1 minute.
- **DC Withstand:** A=70kV, B=100kV, C=125kV negative polarity, 15 minutes.
- **Impulse Withstand (BIL):** A=110kV, B=150kV, C=200kV, 10 positive and 10 negative, 1.2 x 50 microsecond wave, at conductor temperatures of 20° and 130°C, nominal.
- **Short-Time Current:** magnitude equal to cable up to 35kA.
- **Cyclic Aging:** 30 days at: A=26.1kV, B=43.2kV, C=60.6kV AC continuous, load current for 8 hours per day, providing 130° conductor temperature. Joints then subjected to: A=31kV, B=50kV, C=71kV for 5 hours followed by: A=39kV, B=65kV, C=91kV for 5 min.
- **Load Cycle:** Connectors meet requirements of ANSI C119.4, Class A and Class 3 ratings.

DEADFRONT LIVEFRONT	SEPARABLE CONNECTORS	200 AMP LOADBREAK	5-15kV
	FUSED ELBOWS	200 AMP DEADBREAK	25kV
	CABLE JOINTS	600 SERIES DEADBREAK	35kV
	TERMINATIONS		
	SURGE ARRESTERS		

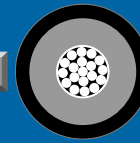

Part numbers that contain the letters **W** or **X** are size sensitive. To complete the part number, refer to the **W** or **X** tables indicated.

PCJ Style 1 with single-piece housing

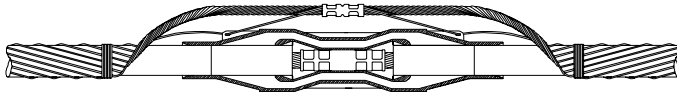

PCJ Style 2 with universal housing and separate cable adapters that can be varied with the cable application.

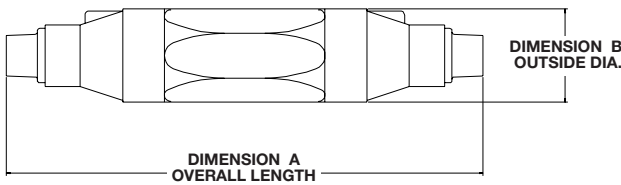
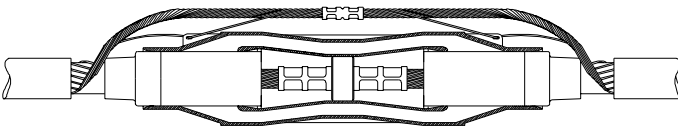

ORDERING INFORMATION

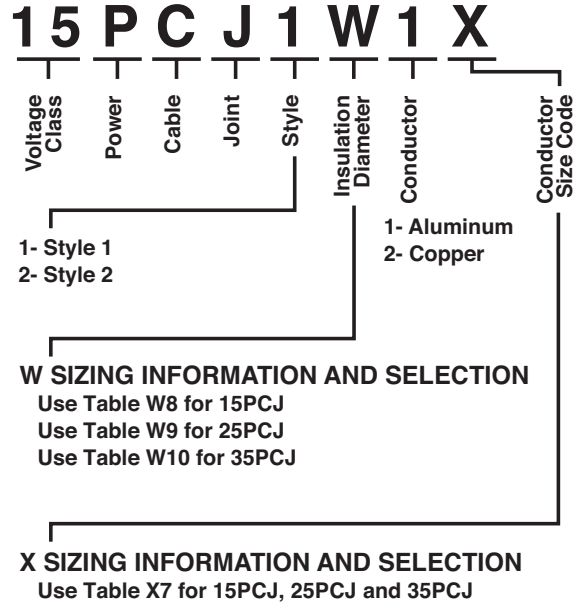

DIMENSIONAL DATA

STYLE 1 PART NUMBER	A	B
	inches	inches
15PCJ1FX	10 1/4"	1 3/4"
15PCJ1GX	10 1/4"	1 3/4"
25PCJ1GX	14 3/8"	2 7/16"
15/25/35PCJ1HX	14 3/8"	2 7/16"
15/25/35PCJ1JX	14 3/8"	2 7/16"
15/25/35PCJ1KX	14 3/8"	2 25/32"
15/25/35PCJ1LX	14 3/8"	2 25/32"
15/25PCJ1LMX	14 3/8"	2 25/32"
15/25/35PCJ1MX	14 3/8"	2 25/32"
15/25/35PCJ1NX	15 3/4"	3 3/16"
15/25/35PCJ1PX	15 3/4"	3 3/16"
15/25/35PCJ1QX	15 3/4"	3 3/16"

STYLE 2 PART NUMBER	A	B
	inches	inches
15PCJ2FX	16 3/8"	2 25/32"
15/25PCJ2GX	16 3/8"	2 25/32"
15/25/35PCJ2HX	16 3/8"	2 25/32"
15/25/35PCJ2JX	16 3/8"	2 25/32"
15/25/35PCJ2KX	21"	3 3/4"
15/25/35PCJ2LX	21"	3 3/4"
15/25/35PCJ2MX	21"	3 3/4"
15/25/35PCJ2NX	21"	3 3/4"
15/25/35PCJ2PX	21"	3 3/4"
15/25/35PCJ2QX	21"	3 3/4"

Description	Voltage Class	ELASTIMOLD Part Number	Notes
Power Cable Joint Style 1	15kV	15PCJ1W1X	N1
	15kV	15PCJ1W2X	N2
	25kV	25PCJ1W1X	N1
	25kV	25PCJ1W2X	N2
	35kV	35PCJ1W1X	N1
	35kV	35PCJ1W2X	N2
Power Cable Joint Style 2	15kV	15PCJ2W1X	N1
	15kV	15PCJ2W2X	N2
	25kV	25PCJ2W1X	N1
	25kV	25PCJ2W2X	N2
	35kV	35PCJ2W1X	N1
	35kV	35PCJ2W2X	N2

- N1. Kit includes aluminum compression connector suitable for splicing aluminum conductor to aluminum conductor or aluminum conductor to copper conductor. An all-copper connector is required for copper to copper connections.
- N2. Kit includes copper compression connector suitable for splicing copper conductors to copper conductor only. DO NOT use copper connectors on aluminum conductors.

Refer to the **W** and **X** tables on pages 34 and 35 for sizing to cable insulation diameter and conductor size.

For cable shield adapters and jacket seals, see page 30.

CABLE TERMINATIONS

Elastimold cable terminations are available in single piece or modular designs. Terminators allow connection and transition from shielded, underground cable to bare overhead conductors and live-front equipment. Units are designed and rated per IEEE Standard 48 for riser pole, padmount, indoor and outdoor applications. PCT1, PCT2, 16THG and 35MTG terminators provide sufficient creep, strike and weather sealing for class 1 outdoor service. PCT1 and PCT2 also include an integral cable jacket seal.

The 35MTGI terminators and 35MSC stress cones are rated for class 2 and class 3 indoor service respectively. Optional mounting brackets, aerial lugs and equipment connectors are available as required.

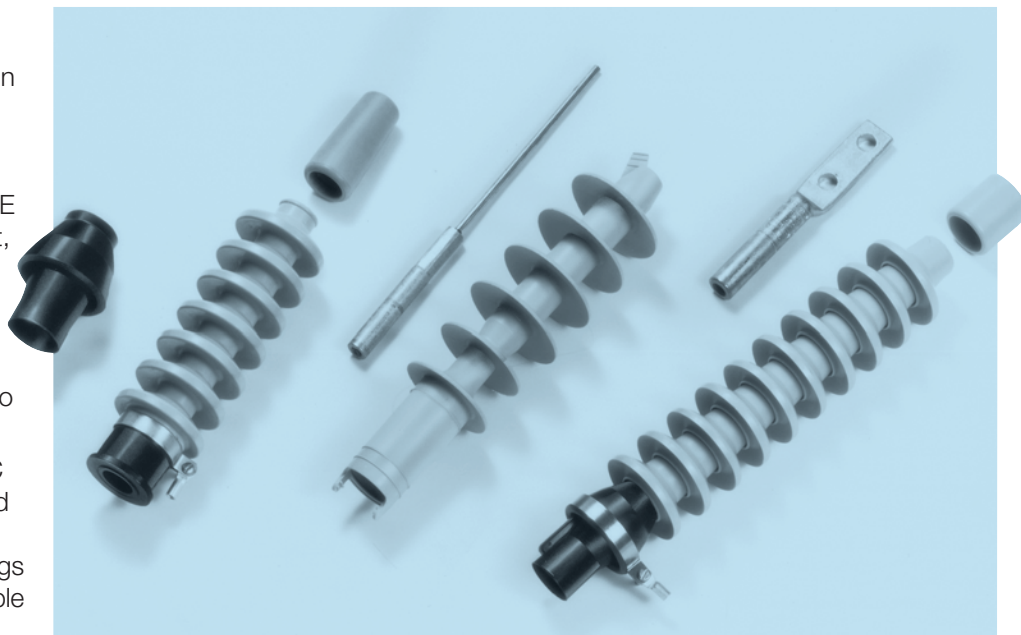

ELECTRICAL RATINGS SUMMARY

The following ratings summary is based on IEEE Std. 48 and applies to all the terminations on page 24 thru 27. Elastimold terminations are designed for use on three-phase systems, either 3-wire or 4-wire and the single-phase laterals of these systems.

VOLTAGE RATINGS

15kV Class

9.5kV Phase-to-Ground
 110kV BIL 1.2 x 50 microsecond wave
 AC Withstand:
 50kV 1 min. – dry
 35kV 6 hr. – dry
 45kV 10 sec. – wet
 13kV Corona Extinction

25kV Class

16kV Phase-to-Ground
 150kV BIL 1.2 x 50 microsecond wave
 AC Withstand:
 65kV 1 min. – dry
 55kV 6 hr. – dry
 60kV 10 sec. – wet
 21.5kV Corona Extinction

35kV Class

22kV Phase-to-Ground
 200kV BIL 1.2 x 50 microsecond wave
 AC Withstand:
 90kV 1 min. – dry
 75kV 6 hr. – dry
 80kV 10 sec. – wet
 30kV Corona Extinction

TERMINATIONS

SINGLE PIECE TERMINATORS

STRESS CONE

MODULAR TERMINATORS

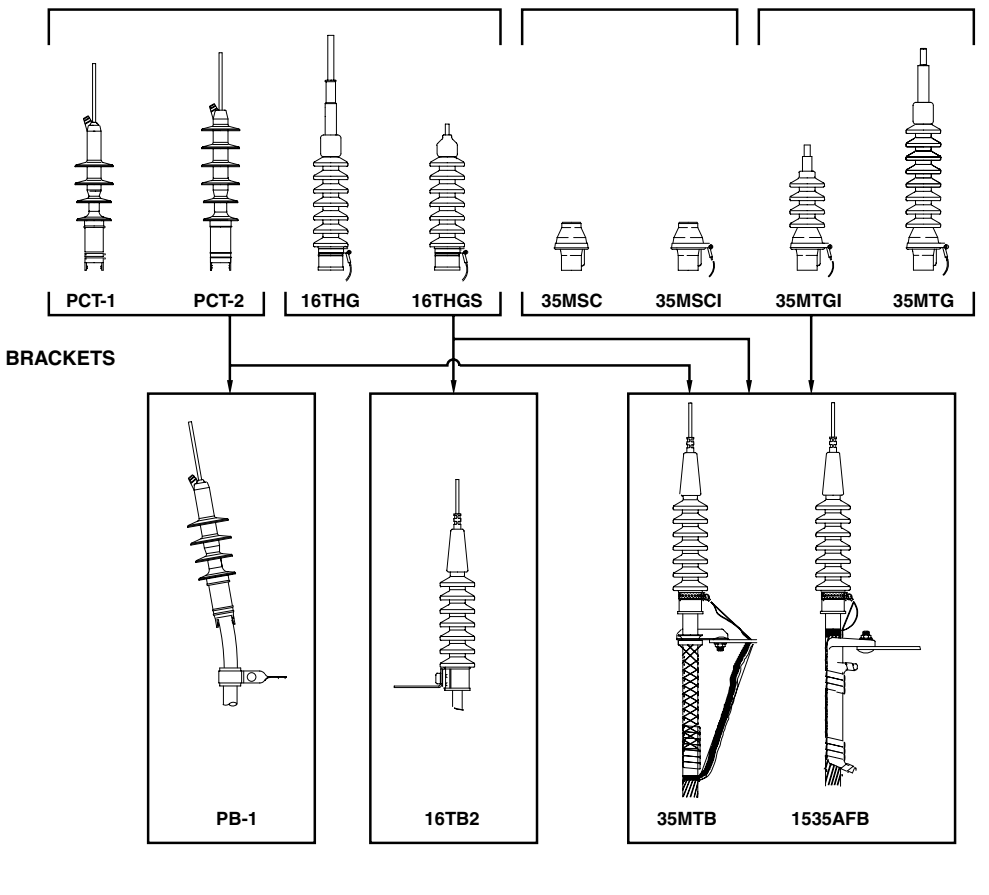

	SEPARABLE CONNECTORS		
DEADFRONT	FUSED ELBOWS	200 AMP LOADBREAK	5-15kV
LIVEFRONT	CABLE JOINTS	200 AMP DEADBREAK	25kV
	TERMINATIONS	600 SERIES DEADBREAK	35kV
	SURGE ARRESTERS		

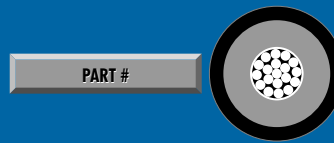

Part numbers that contain the letters **W** or **X** are size sensitive. To complete the part number, refer to the **W** or **X** tables indicated.

TERMINATIONS

Illustration (not to scale)	Description	Voltage Class	ELASTIMOLD Part Number	Notes
	Single-Piece Terminator (Class 1)	15kV 25kV	PCT1-1X-4 Use Table X9 PCT2-1X-4 Use Table X9	N12, 14, 15, 22 N12, 14, 15, 23
	Housing only	15kV 25kV	PCT1-4 PCT2-4	N13, 22 N13, 23
	Single-Piece Terminator (Class 1)	15/25kV	16THG-WX-4 Use Tables W12 and X8	N2, 14 15
	Housing only	15/25kV	16THGH-W Use Table W12	
	Single-Piece Terminator for solid conductor only (Class 1)	15/25kV	16THGS-WX Use Tables W12 and X4	N3
	Stress Cone (Class 3)	ALL	35MSC-W Use Table W11	N17
	Stress Cone w/Grd. Strap	ALL	35MSCI-W Use Table W11	N17
	Modules only	ALL	35MG-W Use Table W13	N11, 16
	Modular Terminator (Class 1)	15kV	35MTG-WX-4-CA Use Tables W13 and X3	N2, 11
		25kV	35MTG-WX-8-CA Use Tables W13 and X3	N2, 5, 11
		35kV	35MTG-WX-10-CA Use Tables W13 and X3	N2, 6, 11
	Modular Terminator (Class 2) w/o Rain Cap	15kV	35MTGI-W-4 Use Table W13	N11
		25kV	35MTGI-W-6 Use Table W13	N11
		35kV	35MTGI-W-8 Use Table W13	N7, 11
	Rod Contact for PCT	15/25kV	0070X Use Table X9	N1, 14, 15
	Rod Contact for 16THG	15/25kV	16TCA-X Use Table X8	N2, 8
	Solid Conductor Package for 16THGS	15/25kV	16CAS-X Use Table X4	N3, 9
	3/4"-16 Threaded Rod for MTG	ALL	35MTGA-WX-1 Use Tables W13 and X3	N2, 10, 11 18, 25
	1"-14 Threaded Rod for MTG	ALL	35MTGA-WX-2 Use Tables W13 and X3A	N2, 10, 11 19, 25
	Two-Hole Spade for MTG	ALL	35MTGA-WX-3 Use Tables W13 and X3	N4, 10, 11 20, 25
	Two-Hole Spade for PCT	ALL	0100X Use Table X9	N1
	One-Hole Spade for PCT	ALL	0110X Use Table X9	N1
	Universal Rod for MTG	ALL	35MTGA-WX-4 Use Tables W13 and X3	N2, 10, 11 21, 25
	Aerial Lugs for MTG Threaded Rod (Two-hole spade or bare wire)	ALL	35AL-A	N10, 24

- N1. Use with PCT1 or PCT2 Terminators.
- N2. Includes contact rod, ground strap and rain cap.
- N3. Includes crimp ring, ground strap and rain cap.
- N4. Includes spade contact, ground strap and rain cap.
- N5. For KA thru PB sizes use 35MTG-WX-6-CA.
- N6. For KA thru PB sizes use 35MTG-WX-8-CA.
- N7. For KA thru PB sizes use 35MTGI-W-6.
- N8. Use with 16THG Terminators.
- N9. Use with 16THGS Terminators.
- N10. Use with 35MTG Terminators.
- N11. Refer to page 26 for detailed ordering instructions.
- N12. Includes rod contact as standard. Specify suffix "-3" in place of "-4" for two-hole spade lug. Specify suffix "-5" in place of "-4" for one-hole spade lug.
- N13. Specify suffix "-3" or "-5" in place of "-4" for two-hole spade lug housing or one-hole spade style housing.
- N14. Use 1X for an aluminum rod contact for aluminum conductors only.
- N15. Substitute 0X for 1X for a universal aluminum rod contact for aluminum or copper conductors.
- N16. Available in sizes from GA thru PB & are supplied qty. 2 per package.
- N17. Available in sizes EB thru PB.
- N18. For conductors from 1/0 thru 350 kcmil.
- N19. For conductors from 400 kcmil thru 1000 kcmil.
- N20. For conductors from #2 to 1000 kcmil.
- N21. For conductors from #6 thru 4/0.
- N22. Use for insulation dia. range from .640" thru 1.070".
- N23. Use for insulation dia. range from .830" thru 1.180".
- N24. Select symbol for "A" from aerial lug ordering information on page 26.
- N25. W13 Table provides sizing for rain cap
X10 Table provides sizing for connectors.

Refer to the **W** and **X** tables on pages 34 and 35 for sizing to cable insulation diameter and conductor size.

For cable shield adapters and jacket seals, see page 30.

CABLE TERMINATIONS cont'd

ORDERING INSTRUCTIONS FOR MODULAR TERMINATORS

35MTG - W X - N - C A

I = Indoor
Blank = Outdoor

Use Table W13, below

Use Table X3 or Table X3A

NOTE: Applicable table and available sizes depend upon connector style. Reference Connector Style Selection Chart and notes A through D.

Recommended Number of Modules

	GA-JB	KA-PB
15kV	4	4
25kV	8	6
35kV	10	8

Connector Style Selection Chart

Description	Available for Conductor Sizes	Symbol	Notes
3/4"-16 Threaded Rod	1/0 thru 350 kcmil	-1	A
1"-14 Threaded Rod	400 thru 1000 kcmil	-2	B
2-Hole Spade	#2 thru 1000 kcmil	-3	C
Universal Rod	#6 thru 4/0	-4	D

Aerial Lugs for Threaded Rod Connectors Only

Type	Connector	Symbol
Bare Wire	3/4"-16 Rod	-11
2-Hole Spade	3/4"-16 Rod	-12
Bare Wire	1"-14 Rod	-21
2-Hole Spade	1"-14 Rod	-22

NOTES:

- A. Available for 1/0 through 350 conductor sizes only. Use Table X3 for size selection.
- B. Available for 400 through 1000 conductor sizes only. Use Table X3A for size selection.
- C. Available for #2 through 1000 conductor sizes only. Use Table X3 for size selection.
- D. Available for #6 through 4/0 conductor sizes only. Use Table X3 for size selection.

Table W13 USE FOR FOLLOWING PRODUCTS 35MTG 35MTGI	Cable Insulation Diameter in Inches		Symbol for W
	MIN.	MAX.	
	.775	.885	GA
	.825	.935	GAB
	.875	.985	GB
	.930	1.040	GH
	.980	1.115	HA
	1.040	1.175	HAB
	1.095	1.240	HB
	1.160	1.305	HJ
	1.220	1.375	JA
	1.285	1.395	JAB
	1.355	1.520	JB
	1.485	1.595	KA
	1.530	1.640	KAB
	1.575	1.685	KB
	1.665	1.785	PA
	1.755	1.875	PB

Table X3 USE FOR FOLLOWING PRODUCT 35MTG FOR USE WITH STYLE -1, -3, & -4 CONNECTORS ONLY. SEE NOTES A, C, & D FOR APPLICATION INFORMATION	Conductor SIZE AWG or kcmil	Symbol for X	
		Strand./Compr.	Compt./Solid.
	#6	5	-
	#5	4	5
	#4	3	4
	#3	2	3
	#2	1	2
	#1	0	1
	1/0	10	0
	2/0	20	10
	3/0	30	20
	4/0	40	30
	250	250	40
	300	300	250
	350	350	300
	400	400	350
	450	450	-
	500	500	400
	550	550	450
	600	600	500
	650	650	550
	700	750	600
	750	750	650
	800	800	750
	900	900	800
	1000	1000	900

Table X3A USE FOR FOLLOWING PRODUCT 35MTG FOR USE WITH STYLE -2 CONNECTORS ONLY. SEE NOTE B FOR APPLICATION INFORMATION	Conductor SIZE AWG or kcmil	Symbol for X	
		Strand./Compr.	Compt./Solid.
	400	400	-
	450	450	400
	500	500	450
	550	550	500
	600	600	500
	650-700	650	550
	750	750	600
	800	750	650
	1000	1000	-

	SEPARABLE CONNECTORS		
DEADFRONT	FUSED ELBOWS	200 AMP LOADBREAK	5-15kV
LIVEFRONT	CABLE JOINTS	200 AMP DEADBREAK	25kV
	TERMINATIONS	600 SERIES DEADBREAK	35kV
	SURGE ARRESTERS		

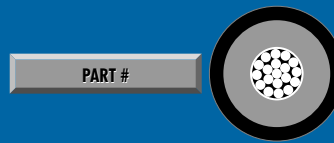

Part numbers that contain the letters **W** or **X** are size sensitive. To complete the part number, refer to the **W** or **X** tables indicated.

TERMINATIONS

Illustration (not to scale)	Description	Voltage Class	ELASTIMOLD Part Number	Notes
	PCT Positioning Bracket	ALL	PB-1	N1,12
	16THG Bracket	ALL	16TB-2	N6
	Bracket for crossarm mounting 16THG	ALL	16TB-3	N6
	Bracket for riser pole mounting 16THG	ALL	16TB-4	N6
	Bracket for tri-mounting 16THG	ALL	16TB-5	N6
	KELLUMS GRIP Bracket	ALL ALL ALL ALL	35MTB1-A 35MTB1-B 35MTB1-C 35MTB1-D	N1,2,6,7 N1,3,6,7 N1,4,6,7 N1,5,6,7
	KELLUMS Bracket for crossarm mounting	ALL ALL ALL ALL	35MTB3-A 35MTB3-B 35MTB3-C 35MTB3-D	N1,2,6,7 N1,3,6,7 N1,4,6,7 N1,5,6,7
	Bracket (for riser pole mounting)	ALL ALL ALL ALL	35MTB4-A 35MTB4-B 35MTB4-C 35MTB4-D	N1,2,6,7 N1,3,6,7 N1,4,6,7 N1,5,6,7
	KELLUMS Bracket for tri-mounting	ALL ALL ALL ALL	35MTB5-A 35MTB5-B 35MTB5-C 35MTB5-D	N1,2,6,7 N1,3,6,7 N1,4,6,7 N1,5,6,7
	ALUMA FORM Bracket	ALL	1535AFB-1	N1,6,7,13
	ALUMA FORM Bracket for Crossarm mounting	ALL	1535AFB-3	N1,6,7,13
	ALUMA FORM Bracket for riser-pole mounting	ALL	1535AFB-4	N1,6,7,13
	ALUMA FORM Bracket for tri-mounting	ALL	1535AFB-5	N1,6,7,13

- N1. Use with PCT-1 or PCT-2 Terminators.
- N2. Fits overall cable O.D. from 1.195" to 1.625".
- N3. Fits overall cable O.D. from .925" to 1.335".
- N4. Fits overall cable O.D. from .890" to 1.185".
- N5. Fits overall cable O.D. from 1.500" to 2.000".
- N6. Use with 16THG & 16THGS Terminators.
- N7. Use with MTG, MTG1 & MSC Terminators.
- N8. For conductors from 1/0 thru 350 kcmil.
- N9. For conductors from 400 kcmil thru 1000 kcmil.
- N10. For conductors from #2 to 1000 kcmil.
- N11. For conductors from #6 thru 4/0.
- N12. Fits overall cable O.D. from .750" to 1.625".
- N13. Fits overall cable O.D. from .750" to 2.000".

Refer to the **W** and **X** tables on pages 34 and 35 for sizing to cable insulation diameter and conductor size.

For cable shield adapters and jacket seals, see page 30.

SURGE ARRESTERS

Thomas and Betts' ELASTIMOLD® Metal Oxide Varistor (MOV) Surge Arresters are fully shielded, fully submersible and are equipped with IEEE 386 interfaces for convenient energized connection with other 200 Amp loadbreak or deadbreak components up to 35kV. Arresters are available in three styles: Elbow (ESA), Parking (PSA) and Bushing (BSA). The PSA and BSA arresters permit direct connection, eliminating the need for additional accessories.

Elastimold MOV Surge Arresters provide high voltage lightning and switching surge protection of transformers, cable, equipment and other components typically located on underground power distribution systems. Proper placement, voltage selection and coordination with riser pole arresters minimizes damaging surge voltages by improving protective margins.

Typical applications include installing an arrester at the end of a radial system, or at both ends of an open point on a loop system. Additional arresters can be added at static locations upstream from the endpoint for optimum protection. Request Form 2068 (Surge Protection Options for Underground Distribution) and Form 2069 (Arrester Applications — Underground Electrical Systems) for additional application and margin of protection information.

ESA Elbow Arresters are also available with a 200 Amp Deadbreak interface for mating with other Deadbreak Accessories.

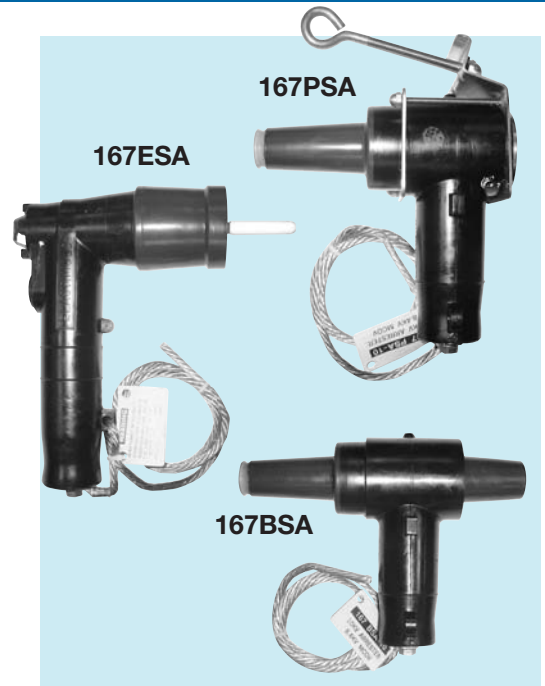

ELECTRICAL RATINGS & PROTECTIVE CHARACTERISTICS

Performance:

High Current Short Duration - All MOV Arresters withstand two discharges of 40kA crest.
 Low Current Long Duration - All MOV Arresters withstand 20 surges of 75 amperes/2000 microsecond duration.

Duty Cycle Test - All MOV Arresters withstand 22 operations of 5kA crest at 8 x 20 microsecond duration while energized at rated voltage for the initial 20 operations and at maximum continuous operating voltage (MCOV) for the final two operations.

Following each of the preceding tests, MOV Arresters demonstrate thermal recovery at MCOV.

PROTECTIVE CHARACTERISTICS:

	MCOV (kVrms) Note 1	Duty Cycle Rating (kVrms)	Maximum Discharge Voltage (kV crest) 8x20 microsecond current wave				
			1.5kA	3kA	5kA	10kA	20kA
15kV CLASS	2.55	3	10.5	11.0	11.5	13.0	14.5
	5.1	6	20.5	21.5	23.0	25.5	30.0
	8.4	10	30.5	32.5	34.5	38.5	43.5
	10.2	12	40.0	42.5	45.0	50.0	56.5
	12.7	15	48.0	51.0	54.0	60.0	68.0
25kV CLASS	15.3	18	56.5	60.0	64.0	71.0	80.5
	8.4	10	30.5	32.5	34.5	38.5	43.5
	10.2	12	40.0	42.5	45.0	50.0	56.5
	12.7	15	48.0	51.0	54.0	60.0	68.0
35kV CLASS	15.3	18	56.5	60.0	64.0	71.0	80.5
	17.0	21	65.5	69.5	74.0	82.5	93.0
	19.5	24	78.5	83.5	89.0	99.0	112.0
	22.0	27	87.5	93.0	99.0	110.0	124.5
	24.4	30	95.5	101.5	108.0	120.0	136.0

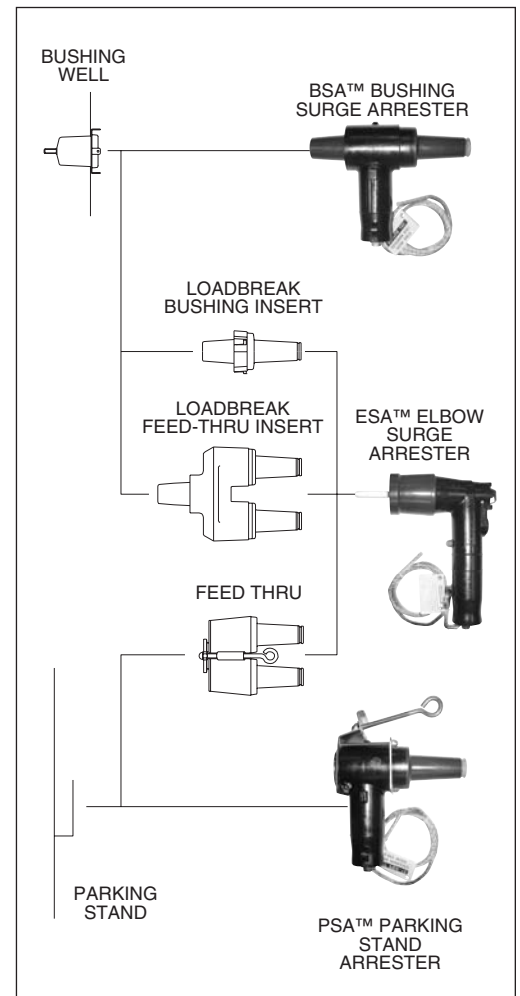

NOTES:

1. MCOV = Maximum Continuous Operating Voltage.



	SEPARABLE CONNECTORS		
DEADFRONT	FUSED ELBOWS	200 AMP LOADBREAK	5-15kV
LIVEFRONT	CABLE JOINTS	200 AMP DEADBREAK	25kV
	TERMINATIONS	600 SERIES DEADBREAK	35kV
	SURGE ARRESTERS		

SELECTION CHART

Illustration (not to scale)	Description	Voltage Class	Elastimold Part Number	MCOV kVrms
	BSA Bushing Surge Arrester (includes assembly tool)	15kV	167BSA-3	2.55
		15kV	167BSA-6	5.10
		15kV	167BSA-10	8.40
		15kV	167BSA-12	10.20
		15kV	167BSA-15	12.70
	See Notes N1,2,3,4	15kV	167BSA-18	15.30
		25kV	273BSA-10	8.40
		25kV	273BSA-12	10.20
		25kV	273BSA-15	12.70
		25kV	273BSA-18	15.30
		25kV	273BSA-21	17.00
		35kV	375BSA-24	19.50
		35kV	375BSA-27	22.00
		35kV	375BSA-30	24.40
	ESA Elbow Surge Arrester	15kV	167ESA-3	2.55
		15kV	167ESA-6	5.10
		15kV	167ESA-10	8.40
		15kV	167ESA-12	10.20
		15kV	167ESA-15	12.70
	See Notes N2,3,5	15kV	167ESA-18	15.30
		25kV	273ESA-10	8.40
		25kV	273ESA-12	10.20
		25kV	273ESA-15	12.70
		25kV	273ESA-18	15.30
		25kV	273ESA-21	17.00
		35kV	375ESA-24	19.50
		35kV	375ESA-27	22.00
		35kV	375ESA-30	24.40
	PSA Parking Stand Arrester	15kV	167PSA-3	2.55
		15kV	167PSA-6	5.10
		15kV	167PSA-10	8.40
		15kV	167PSA-12	10.20
		15kV	167PSA-15	12.70
	See Notes N1,2,3	15kV	167PSA-18	15.30
		25kV	273PSA-10	8.40
		25kV	273PSA-12	10.20
		25kV	273PSA-15	12.70
		25kV	273PSA-18	15.30
		25kV	273PSA-21	17.00
		35kV	375PSA-24	19.50
		35kV	375PSA-27	22.00
		35kV	375PSA-30	24.40

ARRESTER APPLICATION TABLE

	System Line-to-Line Voltage kV rms		MCOV (Max. Continuous Operating Voltage) kV rms	
	Nominal	Max.	Solidly Grounded Neutral Circuits	3-Wire Ungrounded Circuits
15kV Class	2.40	2.54	2.55	2.55
	4.16	4.40	2.55	5.10
	4.80	5.08	5.10	5.10
	6.90	7.26	5.10	8.40
	8.32	8.80	5.10	8.40
	12.47	13.20	8.40	15.30
	13.20	13.97	8.40	15.30
	13.80	14.50	8.40*	15.30
	13.80	14.50	10.20	15.30
	25kV Class	6.90	7.26	5.10
8.32		8.80	5.10	8.40
12.47		13.20	8.40	15.30
13.20		13.97	8.40	15.30
13.80		14.50	8.40*	15.30
13.80		14.50	10.20	15.30
20.78		22.00	12.70	-
20.78		22.00	15.30*	-
23.00		24.34	15.30	-
24.94		26.40	15.30	-
24.94	26.40	17.00*	-	
28.00	29.80	17.00	-	
35kV Class	23.00	24.34	-	22.00
	34.50	36.51	22.00*	-
	34.50	36.51	24.40	-

* Preferred arrester MCOV for this system voltage

- N1. Elastimold PSA and BSA Arresters are equipped with a **fully rated** 200A switching and fault close loadbreak bushing.
- N2. Elastimold Arresters use high-strength silver epoxy bonded MOV blocks and shunted spring connections for the best circuit connection.
- N3. A 36 inch #4 AWG ground lead provided with each unit.
- N4. BSA installed by turning internal hex bolt (accessed thru the 200 Amp Bushing Interface) with 5/16" hex wrench supplied with each unit or 200AT Tool.
- N5. For 15kV and 25kV Class DEADBREAK system Elbow Arresters, use part number 156ESA with the appropriate Duty Cycle rating.

ORDERING INSTRUCTIONS:

- (1.) Determine the appropriate Maximum Continuous Operating Voltage (MCOV) for your system voltage by using the ELASTIMOLD ARRESTER APPLICATION TABLE.
- (2.) Specify the appropriate ELASTIMOLD part number from the selection chart.

SHIELD ADAPTERS, GROUNDING KITS AND JACKET SEALS

Elastimold elbows, cable joints and terminators have been designed for use on XLP, EPR or similar solid dielectric insulated power cables. These cables are available with a variety of optional shielding and jacket constructions. In order to properly mate and install the cable to an Elastimold product, the use of a shield adaptor, grounding kit or jacket seal may be required. The diagram below provides information concerning the application and selection of various shield adaptors, grounding kits and jacket seals for the most popular cable types. Consult the factory for recommendations concerning other cable constructions.

CABLE ENTRANCE DETAIL

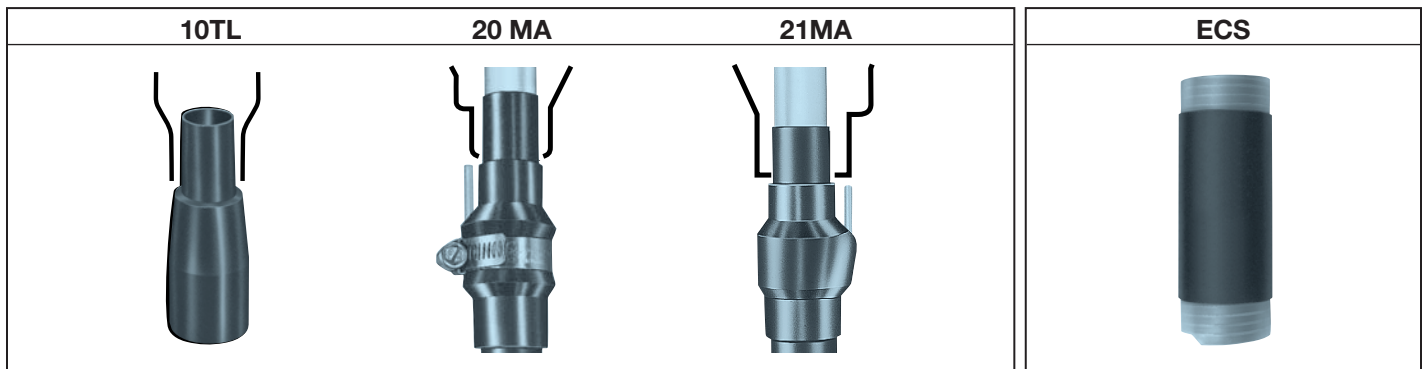
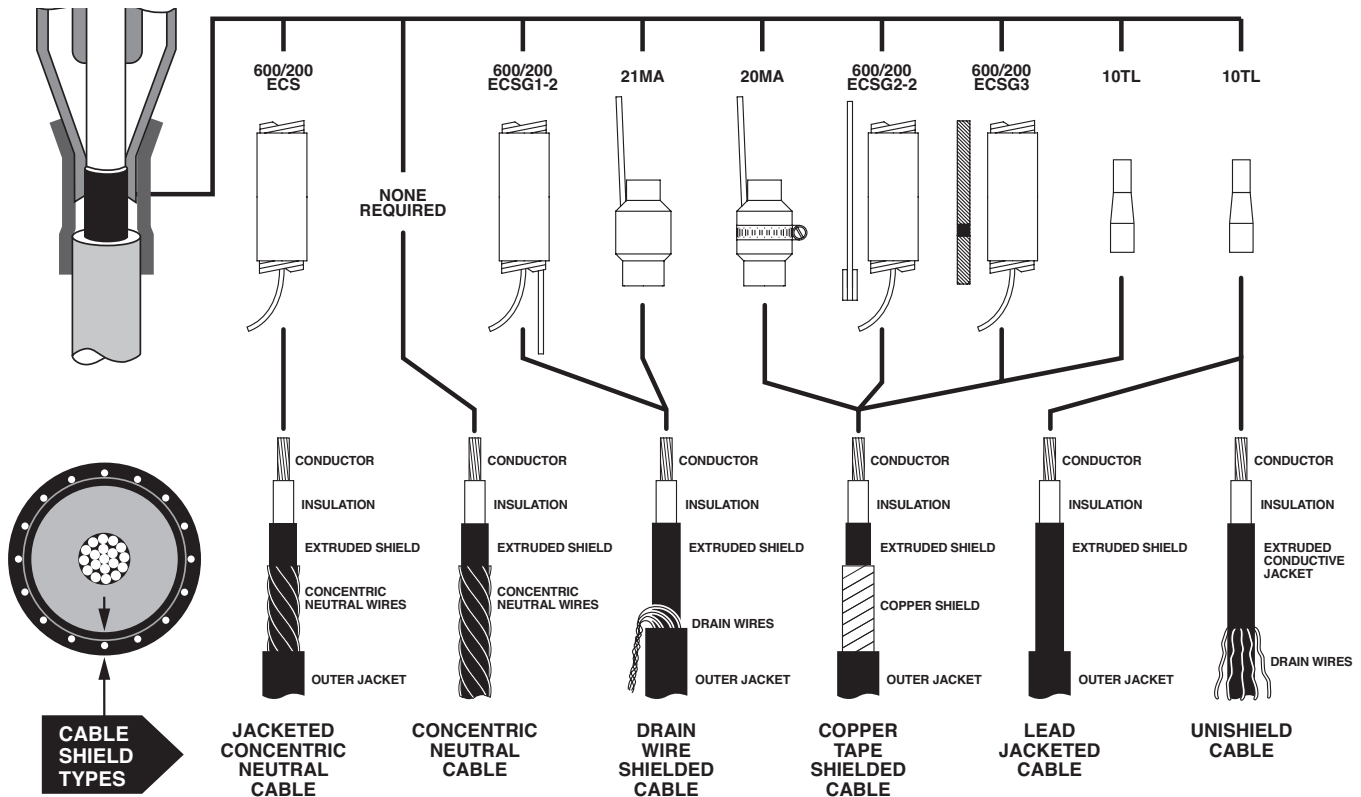
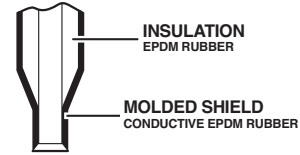

CABLE SHIELD ADAPTERS			
Cable Insulation Dia.	10TL	20MA	21MA
	inches	inches	inches
min.	.495	.530	.530
max.	1.875	1.780	1.780

JACKET SEALS		
Jacket O.D.	200ECS	600ECS
	inches	inches
min.	.80	1.28
max.	1.50	2.30

	SEPARABLE CONNECTORS		
DEADFRONT	FUSED ELBOWS	200 AMP LOADBREAK	5-15kV
LIVEFRONT	CABLE JOINTS	200 AMP DEADBREAK	25kV
	TERMINATIONS	600 SERIES DEADBREAK	35kV
	SURGE ARRESTERS		

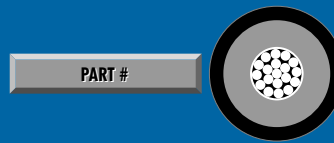

Part numbers that contain the letters **W** or **X** are size sensitive. To complete the part number, refer to the **W** or **X** tables indicated.

Illustration (not to scale)	Description	ELASTIMOLD Part Number	Suffix	Notes
	Cold Shrinkable Jacket Seal	200ECS	-S	N1,3
	Cold Shrinkable Jacket Seal	600ECS	-S	N1,4
	Metallic Tape Shield Adapter	20MA-W Use Table W14 for sizing	-OMA	N1,2,5,6
	Wire Shield Adapter	21MA-W Use Table W14 for sizing	-1MA	N1,2,5,6
	Shield Adapter	10TL-W Use Table W15 for sizing	-TL	N1,2
	Cold Shrinkable Seal w/ Copper Rod & Crimp Connector	200ECSG1-2	-SG1	N1,3,5,6
	Cold Shrinkable Seal w/ Copper Rod & Crimp Connector	600ECSG1-2	-SG1	N1,4,5,6
	Cold Shrinkable Seal w/ Copper Rod & Constant Force Spring	200ECSG2-2	-SG2	N1,3,5,6
	Cold Shrinkable Seal w/ Copper Rod & Constant Force Spring	600ECSG2-2	-SG2	N1,4,5,6
	Cold Shrinkable Seal w/ Copper Braid & Constant Force Spring	200ECSG3	-SG3	N1,3,5,7
	Cold Shrinkable Seal w/ Copper Braid & Constant Force Spring	600ECSG3	-SG3	N1,4,5,7

- N1. To order the kits as separate items, use the part numbers shown in the table. Example: To order a cold shrinkable tube as a separate item, use the part number 200ECS.
To order the kits as components of other items, add the suffix to the end of the part number. Example: To order a cold shrinkable jacket seal as a component of an elbow kit, use the part number 166LR-A5200-S.
- N2. Only use this suffix with part numbers that designate a "W" housing size. Sizing the main component will also size the suffix adapter.
- N3. Size range .80" to 1.50" jacket diameters. Maximum installed diameter is approx. 2".
- N4. Size range 1.28" to 2.30" jacket diameters. Maximum installed diameter is approx. 2.75".
- N5. Voltage rating equal to Elastimold product being used.
- N6. Copper rod size is no. 6 for sizes FA thru HA and no. 2 for sizes HAB thru JB.
- N7. Braid is equivalent to no. 6 copper rod for sizes FA thru HA and no. 2 copper rod for sizes HAB thru JB.

Table W14 USE FOR 20MA 21MA	Insulation Inches		Symbol for W
	MIN.	MAX.	
		.530	.680
	.640	.820	F
	.760	.950	G
	.850	1.050	H
	.980	1.180	J
	1.090	1.310	K
	1.180	1.465	L
	1.370	1.630	M
	1.515	1.780	N

Table W15 USE FOR 10TL	Insulation Inches		Symbol for W
	MIN.	MAX.	
		.495	.585
	.525	.635	EF
	.575	.585	FA
	.625	.735	FAB
	.675	.785	FB
	.725	.835	FG
	.775	.885	GA
	.825	.935	GAB
	.875	.985	GB
	.930	1.040	GH
	.980	1.115	HA
	1.040	1.175	HAB
	1.095	1.240	HB
	1.160	1.305	HJ
	1.220	1.375	JA
	1.285	1.395	JAB
	1.355	1.520	JB
	1.485	1.595	KA
	1.530	1.640	KAB
	1.575	1.685	KB
	1.755	1.875	PB

How to specify Size-Sensitive Products

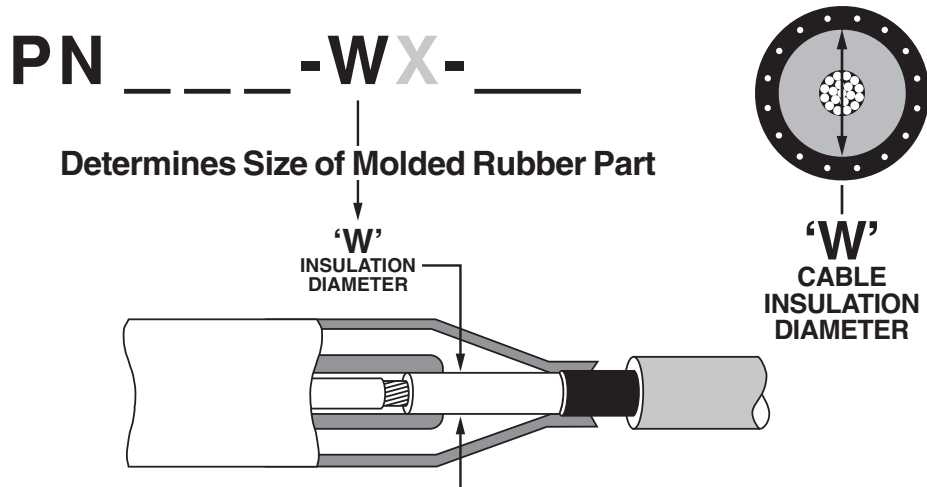

INSULATION DIAMETER SELECTION GUIDE

Elastimold Elbows, cable joints and terminations are designed for application on XLP, EPR and other solid dielectric insulated power cables. These components are constructed of molded elastomer and rely on an interference fit with the cable insulation diameter in order to maintain proper dielectric strength, creep path integrity and a water seal. Elastimold components are available in a wide range of sizes in order to accommodate a variety of cable insulation diameters.

Selection of size-sensitive components requires determining the cable insulation diameter. This can be done in several ways:

- A. Refer to the cable manufacturer's spec sheet for dimensions.
- B. Measure the cable.
- C. If the cable conforms to AEIC or ICEA standards and is:
 1. 15kV, 175 mil wall thickness, use the table on page 36.
 2. 15kV, 220 mil wall thickness, use the table on page 37.
 3. 25kV, 260 mil wall thickness, use the table on page 38.
 4. 35kV, 345 mil wall thickness, use the table on page 39.

After the cable insulation diameter minimum and maximum has been determined:

1. Locate the W table indicated in the part number selection chart.
2. Complete the ordering information by selecting and inserting the symbol (given in the W table) into the part number.

Ordering Examples

AEIC

To complete the information required to order a K655LR-W0X elbow for use on standard AEIC 1000 kcmil stranded aluminum cable with .260 inch thick insulation wall:

- A. Determine that the insulation diameter (for AEIC cable in the table on page 38) is 1.730 – 1.790 inches.
- B. For this elbow, the part number selection chart on page 11 indicates to use table W7 for elbow sizing and table X6 for connector sizing.
- C. From table W7 the symbol for W is **P**.
- D. From table X6 the symbol for X is **410**.
- E. The completed part number therefore is K655LR-**P0410**.

ICEA

To complete the information required to order a K655LR-W0X elbow for use on standard ICEA 1000 kcmil stranded aluminum cable with .260 inch thick insulation wall:

- A. Determine that the insulation diameter (for ICEA cable in the table on page 38) is 1.680 – 1.775 inches.
- B. For this elbow, the part number selection chart on page 11 indicates to use table W7 for elbow sizing and table X6 for connector sizing.
- C. From table W7 the symbol for W is **N**.
- D. From table X6 the symbol for X is **410**.
- E. The completed part number therefore is K655LR-**N0410**.

	SEPARABLE CONNECTORS			
DEADFRONT	FUSED ELBOWS	200 AMP LOADBREAK	5-15kV	PART #
LIVEFRONT	CABLE JOINTS	200 AMP DEADBREAK	25kV	
	TERMINATIONS	600 SERIES DEADBREAK	35kV	
	SURGE ARRESTERS			

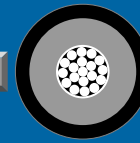

Part numbers that contain the letters W or X are size sensitive. To complete the part number, refer to the W or X tables indicated.

PN ____ -WX- ____

Determines Crimp Connector Size

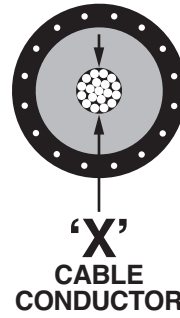
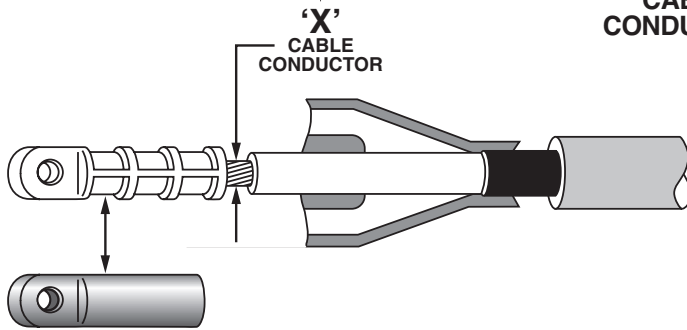

PN ____ -WX- ____

'Suffix'

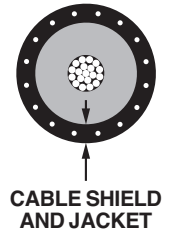

Determines Required Accessories (if any)

- Cable Shield Adaptors
- Cable Grounding Kits
- Cable Jacket Seal

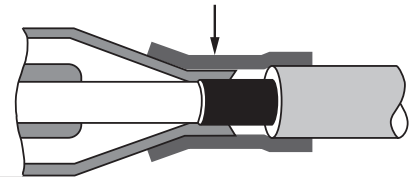

Reference Pages 30 & 31 for application, selection and ordering information.

CONNECTOR SELECTION GUIDE

Elastimold elbows, cable joints and terminations are furnished with crimp style cable connectors. As standard, these connectors are constructed with a tin-plated aluminum barrel filled with an oxide inhibitor. Most aluminum barrel connectors are universal and are designed for use on either aluminum or copper conductor cable.

When specified, all copper crimp style connectors can be furnished. These connectors are ONLY for use on copper conductor cable and are not for use with aluminum conductor cables. Bi-metallic connectors are constructed with a copper top and an aluminum barrel. Bi-metal connectors can be used on either aluminum or copper conductor cable and are furnished as standard with 200 Amp Loadbreak Elbows, 200 Amp Deadbreak Elbows, and PCT, 16 THG or MTG terminators with rod connectors.

Aluminum connectors used in PCJ Cable Joints are rated as follows:

- Aluminum conductor to aluminum conductor, cable rated
- Aluminum conductor to copper conductor, cable rated equal to the aluminum cable

Copper connectors used in PCJ Cable Joints are rated as follows:

- Copper conductor to copper conductor, cable rated

Selection and ordering the proper crimp connector requires determining information relative to the cable conductor as follows:

- Conductor size in AWG or kcmil
- Conductor type (stranded, compressed, compact or solid)
- Conductor material (aluminum or copper)

After the cable conductor information has been determined:

- Locate the X table indicated in the part number selection chart.
- Complete the ordering information by selecting and inserting the symbol (given in the X table) into the part number.

See the Ordering Example on page 32 for further information.

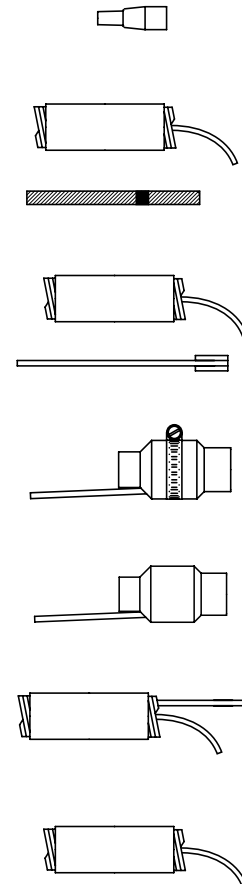

WX SIZE TABLES

“W”
INSULATION
DIAMETER

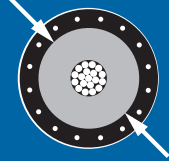

Table W1 USE FOR FOLLOWING PRODUCTS 165/166LR 165/166LRJS	Cable Insulation Diameter in Inches		Symbol for W
	MIN.	MAX.	
	.575	.740	A
	.635	.905	B
	.830	1.060	C
	.930	1.220	D

Table W1A USE FOR FOLLOWING PRODUCTS 151SP/SR 151LS/LY	Cable Insulation Diameter in Inches		Symbol for W
	MIN.	MAX.	
	.575	.740	A
	.635	.905	B
	.805	1.060	C
	.890	1.220	D

Table W2 USE FOR FOLLOWING PRODUCTS 273RLR 274RLR	Cable Insulation Diameter in Inches		Symbol for W
	MIN.	MAX.	
	.760	.950	G
	.850	1.050	H
	.980	1.180	J
	1.090	1.310	K

Table W3 USE FOR FOLLOWING PRODUCTS 375RLR 376RLR	Cable Insulation Diameter in Inches		Symbol for W
	MIN.	MAX.	
	.850	1.050	H
	.980	1.180	J
	1.090	1.310	K
	1.235	1.465	L

Table W4 USE FOR FOLLOWING PRODUCTS 156LR 167/168RLR 167LRT	Cable Insulation Diameter in Inches		Symbol for W
	MIN.	MAX.	
	.640	.820	F
	.760	.950	G
	.850	1.050	H
	.980	1.180	J
	1.090	1.310	K

Table W5 USE FOR FOLLOWING PRODUCTS 167/168ELR 273/274ELR	Cable Insulation Diameter in Inches		Symbol for W
	MIN.	MAX.	
	.665	.895	6689
	.740	.950	7495
	.880	1.100	88110
	1.090	1.310	K

Table W6 USE FOR FOLLOWING PRODUCTS 10EP 152EA 160CA* (*EB - FA Only)	Cable Insulation Diameter in Inches		Symbol for W
	MIN.	MAX.	
	.495	.585	EB
	.525	.635	EF
	.575	.685	FA
	.625	.735	FAB
	.675	.785	FB
	.725	.835	FG
	.775	.885	GA
	.825	.935	GAB
	.875	.985	GB

Table W7 USE FOR FOLLOWING PRODUCTS K656I/CY/CH K655/656LR K655/656SR 655/656LINK K655/656LINK 655/656ETP K655/656ETP 655/656RTP K655/656L RTP 655/656BI-LINK K655/656BI-LINK 655CA/CK/TCK	Cable Insulation Diameter in Inches		Symbol for W
	MIN.	MAX.	
	.640	.820	F
	.760	.950	G
	.850	1.050	H
	.980	1.180	J
	1.090	1.310	K
	1.180	1.465	L
	1.280	1.430	LM
	1.370	1.630	M
	1.515	1.780	N
	1.725	1.935	P

Table W8 USE FOR FOLLOWING PRODUCTS 15PCJ-1 15PCJ-2	Cable Insulation Diameter in Inches		Symbol for W
	MIN.	MAX.	
	.640	.820	F
	.760	.950	G
	.850	1.050	H
	.980	1.180	J
	1.090	1.310	K
	1.180	1.465	L
	1.280	1.430	LM
	1.370	1.630	M
	1.515	1.780	N
	1.725	1.935	P
	1.900	2.120	Q

Table W9 USE FOR FOLLOWING PRODUCTS 25PCJ-1 25PCJ-2 755/756LR 755/756LINK 755/756ETP 755/756L RTP 755/756BI-LINK 755CA/CK/TCK	Cable Insulation Diameter in Inches		Symbol for W
	MIN.	MAX.	
	.760	.950	G
	.850	1.050	H
	.980	1.180	J
	1.090	1.310	K
	1.180	1.465	L
	1.280	1.430	LM
	1.370	1.630	M
	1.515	1.780	N
	1.725	1.935	P
	1.900	2.120	Q

Table W10 USE FOR FOLLOWING PRODUCTS 35PCJ-1 35PCJ-2	Cable Insulation Diameter in Inches		Symbol for W
	MIN.	MAX.	
	.850	1.050	H
	.980	1.180	J
	1.090	1.310	K
	1.180	1.465	L
	1.280	1.430	LM
	1.370	1.630	M
	1.515	1.780	N
	1.725	1.935	P
	1.900	2.120	Q

Table W11 USE FOR FOLLOWING PRODUCTS 35MSC 35MSCI	Cable Insulation Diameter in Inches		Symbol for W
	MIN.	MAX.	
	.495	.585	EB
	.525	.635	EF
	.575	.685	FA
	.625	.735	FAB
	.675	.785	FB
	.725	.835	FG
	.775	.885	GA
	.825	.935	GAB
	.875	.985	GB
	.930	1.040	GH
	.980	1.115	HA
	1.040	1.175	HAB
	1.095	1.240	HB
	1.160	1.305	HJ
	1.220	1.375	JA
	1.285	1.395	JAB
	1.355	1.520	JB
	1.485	1.595	KA
	1.530	1.640	KAB
	1.575	1.685	KB
	1.665	1.785	PA
	1.755	1.875	PB

Table W12 USE FOR FOLLOWING PRODUCTS 16THG 16THGS 16THGH	Cable Insulation Diameter in Inches		Symbol for W
	MIN.	MAX.	
	.495	.585	EB
	.525	.635	EF
	.575	.685	FA
	.625	.735	FAB
	.675	.785	FB
	.725	.835	FG
	.775	.885	GA
	.825	.935	GAB
	.875	.985	GB
	.930	1.040	GH
	.980	1.115	HA

Table W16 USE FOR FOLLOWING PRODUCTS 275/276LR 275/276LRJS	Cable Insulation Diameter in Inches		Symbol for W
	MIN.	MAX.	
	.800	1.060	CC
	.940	1.170	DD

Please see page 26 for Table W13 and page 31 for Tables W14 and W15.

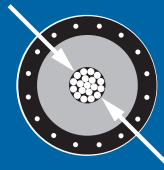

Table X1 USE FOR FOLLOWING PRODUCTS 167/168ELR 273/274ELR 156LR 165/166LR 273/274LR 167LRT 167/168RLR 273/274RLR 00400 02500 02509 02702 02800 K151SP/SR K151LS/LY	Conductor Size AWG or kcmil	Symbol for X	
		Strand./Compr.	Compt./Solid.
#4	200	190	
#3	210	200	
#2	220	210	
#1	230	220	
1/0	240	230	
2/0	250	240	
3/0	260	250	
4/0	270	260	
250	—	270	

Table X2 USE FOR FOLLOWING PRODUCTS 375/376LR	Conductor Size AWG or kcmil	Symbol for X	
		Strand./Compr.	Compt./Solid.
1/0	240	230	
2/0	250	240	
3/0	260	250	
4/0	270	260	

Table X3 USE FOR FOLLOWING PRODUCTS 35MTG NOTE: SEE PAGE 24 FOR DETAILED APPLICATION INFORMATION	Conductor Size AWG or kcmil	Symbol for X	
		Strand./Compr.	Compt./Solid.
#6	5	—	
#5	4	5	
#4	3	4	
#3	2	3	
#2	1	2	
#1	0	1	
1/0	10	0	
2/0	20	10	
3/0	30	20	
4/0	40	30	
250	250	40	
300	300	250	
350	350	300	
400	400	350	
450	450	—	
500	500	400	
550	550	450	
600	600	500	
650	650	550	
700	750	600	
750	750	650	
800	800	750	
900	900	800	
1000	1000	900	

Table X3A USE FOR FOLLOWING PRODUCTS 35MTG NOTE: SEE PAGE 24 FOR DETAILED APPLICATION INFORMATION	Conductor Size AWG or kcmil	Symbol for X	
		Strand./Compr.	Compt./Solid.
400	400	—	
450	450	400	
500	500	450	
550	550	500	
600	600	500	
650-700	650	550	
750	750	600	
800	750	650	
1000	1000	—	

Table X4 USE FOR FOLLOWING PRODUCTS 16THGS 16CAS	Riser Conductor Size AWG Solid	Symbol for X
#2	2	
#1	2	
1/0	10	
2/0	20	
3/0	30	
4/0	30	

Table X6 USE FOR FOLLOWING PRODUCTS 655/656LRTP K655/656LRTP 755/756LRTP K6561/Y/H K655/656LR 755/756LR K655/656SR 655/656LINK K655/656LINK 755/756LINK 655/656ETP K655/656ETP 755/756ETP 655/656BI-LINK K655/656BI-LINK 755BI-LINK 655CK 755CK 655TCK 03600 03602 03700 03702	Conductor Size AWG or kcmil	Symbol for X	
		Strand./Compr.	Compt./Solid.
#2	220	210	
#1	230	220	
1/0	240	230	
2/0	250	240	
3/0	260	250	
4/0	270	260	
250	280	270	
300	290	280	
350	300	290	
400	310	300	
450	320	310	
500	330	320	
550	340	320	
600	350	330	
650	360	340	
700	380	350	
750	380	360	
800	390	360	
900	400	380	
1000	410	400	
1250	440	420	

Table X7 USE FOR FOLLOWING PRODUCTS 15PCJ1 25PCJ1 35PCJ1 15PCJ2 25PCJ2 35PCJ2	Conductor Size AWG or kcmil	Symbol for X	
		Strand./Compr.	Compt./Solid.
#6	180	—	
#5	190	180	
#4	200	190	
#3	210	200	
#2	220	210	
#1	230	220	
1/0	240	230	
2/0	250	240	
3/0	260	250	
4/0	270	260	
250	280	270	
300	290	280	
350	300	290	
400	310	300	
450	320	310	
500	330	310	
550	340	320	
600	350	330	
650	360	340	
700	380	350	
750	380	360	
800	390	380	
900	400	380	
1000	410	400	
1250	440	420	

Table X8 USE FOR FOLLOWING PRODUCTS 16THG 16TCA	Conductor Size AWG or kcmil	Symbol for X	
		Strand./Compr.	Compt./Solid.
#6	180	—	
#5	190	180	
#4	200	190	
#3	210	200	
#2	220	210	
#1	230	220	
1/0	240	230	
2/0	250	240	
3/0	260	250	
4/0	270	260	

Table X9 USE FOR FOLLOWING PRODUCTS PCT1 PCT2 01000 01010	Conductor Size AWG or kcmil	Symbol for X	
		Strand./Compr.	Compt./Solid.
#2	220	210	
#1	230	220	
1/0	240	230	
2/0	250	240	
3/0	260	250	
4/0	270	260	

AEIC and ICEA CABLE INSULATION DIAMETER REFERENCE

15kV 100% — 175 mil Insulation

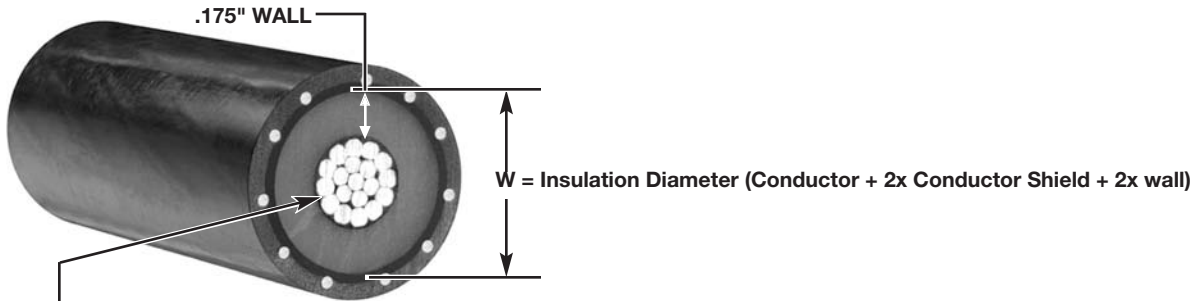

		INSULATION DIAMETER							
Conductor Size	Industry Standard	w/Solid Conductor		w/Stranded Conductor		w/Compressed Conductor		w/Compact Conductor	
		Min.	Max.	Min.	Max.	Min.	Max.	Min.	Max.
2	AEIC CS8-00	0.640	0.700	0.670	0.730	0.665	0.725	0.650	0.710
	ICEA S-97-682-2000	0.610	0.695	0.645	0.730	0.635	0.720	0.620	0.705
1	AEIC CS8-00	0.670	0.730	0.710	0.770	0.700	0.760	0.680	0.740
	ICEA S-97-682-2000	0.645	0.725	0.685	0.770	0.675	0.760	0.655	0.735
1/0	AEIC CS8-00	0.705	0.765	0.755	0.815	0.740	0.800	0.715	0.775
	ICEA S-97-682-2000	0.680	0.760	0.725	0.810	0.715	0.800	0.690	0.775
2/0	AEIC CS8-00			0.800	0.860	0.785	0.845	0.755	0.815
	ICEA S-97-682-2000			0.775	0.855	0.760	0.845	0.730	0.815
3/0	AEIC CS8-00			0.850	0.910	0.835	0.895	0.805	0.865
	ICEA S-97-682-2000			0.825	0.905	0.810	0.895	0.775	0.860
4/0	AEIC CS8-00			0.910	0.970	0.890	0.950	0.855	0.915
	ICEA S-97-682-2000			0.880	0.965	0.865	0.950	0.830	0.910
250	AEIC CS8-00			0.965	1.025	0.950	1.010	0.910	0.970
	ICEA S-97-682-2000			0.935	1.020	0.920	1.005	0.880	0.965
350	AEIC CS8-00			1.070	1.130	1.050	1.110	1.005	1.065
	ICEA S-97-682-2000			1.045	1.130	1.025	1.110	0.980	1.065
500	AEIC CS8-00			1.205	1.265	1.180	1.240	1.125	1.185
	ICEA S-97-682-2000			1.175	1.260	1.150	1.235	1.100	1.185
600	AEIC CS8-00			1.295	1.355	1.265	1.325	1.215	1.275
	ICEA S-97-682-2000			1.265	1.350	1.235	1.325	1.185	1.270
700	AEIC CS8-00			1.365	1.425	1.335	1.395	1.275	1.335
	ICEA S-97-682-2000			1.335	1.420	1.305	1.390	1.245	1.335
750	AEIC CS8-00			1.400	1.460	1.370	1.430	1.310	1.370
	ICEA S-97-682-2000			1.370	1.455	1.340	1.425	1.280	1.365
800	AEIC CS8-00			1.430	1.490	1.400	1.460	1.340	1.400
	ICEA S-97-682-2000			1.400	1.490	1.370	1.455	1.310	1.395
900	AEIC CS8-00			1.495	1.550	1.460	1.520	1.400	1.460
	ICEA S-97-682-2000			1.465	1.555	1.430	1.520	1.370	1.455
1000	AEIC CS8-00			1.550	1.610	1.515	1.575	1.460	1.520
	ICEA S-97-682-2000			1.520	1.610	1.485	1.575	1.430	1.515

AEIC and ICEA CABLE INSULATION DIAMETER REFERENCE

15kV 133% — 220 mil Insulation

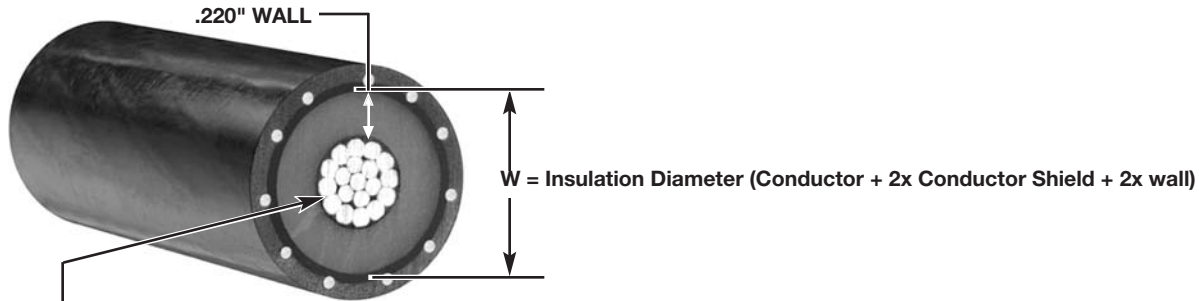

		INSULATION DIAMETER							
Conductor Size	Industry Standard	w/Solid Conductor		w/Stranded Conductor		w/Compressed Conductor		w/Compact Conductor	
		Min.	Max.	Min.	Max.	Min.	Max.	Min.	Max.
2	AEIC CS8-00	0.730	0.790	0.760	0.820	0.755	0.815	0.740	0.800
	ICEA S-97-682-2000	0.700	0.790	0.735	0.825	0.725	0.815	0.710	0.800
1	AEIC CS8-00	0.760	0.820	0.800	0.860	0.790	0.850	0.770	0.830
	ICEA S-97-682-2000	0.735	0.820	0.775	0.865	0.765	0.855	0.745	0.830
1/0	AEIC CS8-00	0.795	0.855	0.845	0.905	0.830	0.890	0.805	0.865
	ICEA S-97-682-2000	0.770	0.855	0.815	0.905	0.805	0.895	0.780	0.865
2/0	AEIC CS8-00			0.890	0.950	0.875	0.935	0.845	0.905
	ICEA S-97-682-2000			0.865	0.950	0.850	0.935	0.820	0.905
3/0	AEIC CS8-00			0.940	1.000	0.925	0.985	0.895	0.955
	ICEA S-97-682-2000			0.915	1.000	0.900	0.985	0.865	0.955
4/0	AEIC CS8-00			1.000	1.060	0.980	1.040	0.945	1.005
	ICEA S-97-682-2000			0.970	1.060	0.955	1.045	0.920	1.005
250	AEIC CS8-00			1.055	1.115	1.040	1.100	1.000	1.060
	ICEA S-97-682-2000			1.025	1.115	1.010	1.100	0.970	1.060
350	AEIC CS8-00			1.160	1.220	1.140	1.200	1.095	1.155
	ICEA S-97-682-2000			1.135	1.220	1.115	1.200	1.070	1.155
500	AEIC CS8-00			1.295	1.355	1.270	1.330	1.215	1.275
	ICEA S-97-682-2000			1.265	1.355	1.240	1.330	1.190	1.275
600	AEIC CS8-00			1.385	1.445	1.355	1.415	1.305	1.365
	ICEA S-97-682-2000			1.355	1.445	1.325	1.415	1.275	1.365
700	AEIC CS8-00			1.455	1.515	1.425	1.485	1.365	1.425
	ICEA S-97-682-2000			1.425	1.515	1.395	1.485	1.335	1.430
750	AEIC CS8-00			1.490	1.550	1.460	1.520	1.400	1.460
	ICEA S-97-682-2000			1.460	1.550	1.430	1.520	1.370	1.460
800	AEIC CS8-00			1.520	1.580	1.490	1.550	1.430	1.490
	ICEA S-97-682-2000			1.490	1.580	1.460	1.550	1.400	1.490
900	AEIC CS8-00			1.585	1.645	1.550	1.610	1.490	1.550
	ICEA S-97-682-2000			1.555	1.645	1.520	1.610	1.460	1.550
1000	AEIC CS8-00			1.640	1.700	1.605	1.665	1.550	1.610
	ICEA S-97-682-2000			1.610	1.705	1.575	1.670	1.520	1.610

AEIC and ICEA CABLE INSULATION DIAMETER REFERENCE

25kV 100% — 260 mil Insulation

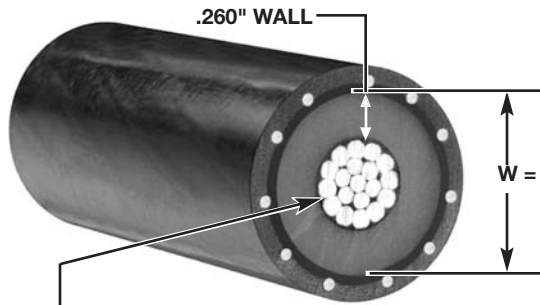

W = Insulation Diameter (Conductor + 2x Conductor Shield + 2x wall)

		INSULATION DIAMETER							
Conductor Size	Industry Standard	w/Solid Conductor		w/Stranded Conductor		w/Compressed Conductor		w/Compact Conductor	
		Min.	Max.	Min.	Max.	Min.	Max.	Min.	Max.
2	AEIC CS8-00								
	ICEA S-97-682-2000								
1	AEIC CS8-00	0.840	0.900	0.880	0.940	0.870	0.930	0.850	0.910
	ICEA S-97-682-2000	0.805	0.895	0.845	0.935	0.835	0.925	0.815	0.905
1/0	AEIC CS8-00	0.875	0.935	0.925	0.985	0.910	0.970	0.885	0.945
	ICEA S-97-682-2000	0.840	0.930	0.885	0.980	0.875	0.965	0.850	0.940
2/0	AEIC CS8-00			0.970	1.030	0.955	1.015	0.925	0.985
	ICEA S-97-682-2000			0.935	1.025	0.920	1.010	0.890	0.980
3/0	AEIC CS8-00			1.020	1.080	1.005	1.065	0.975	1.035
	ICEA S-97-682-2000			0.985	1.075	0.970	1.060	0.935	1.030
4/0	AEIC CS8-00			1.080	1.140	1.060	1.120	1.025	1.085
	ICEA S-97-682-2000			1.040	1.135	1.025	1.115	0.990	1.080
250	AEIC CS8-00			1.145	1.205	1.130	1.190	1.090	1.150
	ICEA S-97-682-2000			1.095	1.190	1.080	1.175	1.040	1.135
350	AEIC CS8-00			1.250	1.310	1.230	1.290	1.185	1.245
	ICEA S-97-682-2000			1.205	1.295	1.185	1.275	1.140	1.230
500	AEIC CS8-00			1.385	1.445	1.360	1.420	1.305	1.365
	ICEA S-97-682-2000			1.335	1.430	1.310	1.405	1.260	1.350
600	AEIC CS8-00			1.475	1.535	1.445	1.505	1.395	1.455
	ICEA S-97-682-2000			1.425	1.520	1.395	1.490	1.345	1.440
700	AEIC CS8-00			1.545	1.605	1.515	1.575	1.455	1.515
	ICEA S-97-682-2000			1.495	1.590	1.465	1.560	1.405	1.500
750	AEIC CS8-00			1.580	1.640	1.550	1.610	1.490	1.550
	ICEA S-97-682-2000			1.530	1.625	1.500	1.595	1.440	1.535
800	AEIC CS8-00			1.610	1.670	1.580	1.640	1.520	1.580
	ICEA S-97-682-2000			1.560	1.655	1.530	1.625	1.470	1.565
900	AEIC CS8-00			1.675	1.735	1.640	1.700	1.580	1.640
	ICEA S-97-682-2000			1.625	1.720	1.590	1.685	1.530	1.625
1000	AEIC CS8-00			1.730	1.790	1.695	1.755	1.640	1.700
	ICEA S-97-682-2000			1.680	1.775	1.645	1.740	1.590	1.685

AEIC and ICEA CABLE INSULATION DIAMETER REFERENCE

35kV 100% — 345 mil Insulation

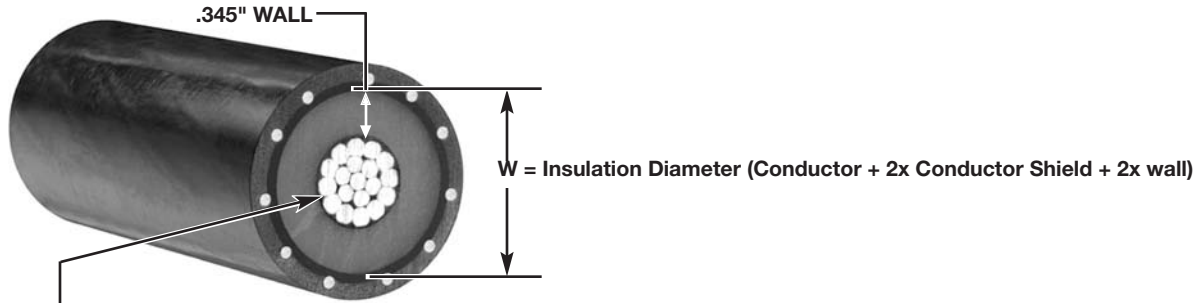

		INSULATION DIAMETER							
Conductor Size	Industry Standard	w/Solid Conductor		w/Stranded Conductor		w/Compressed Conductor		w/Compact Conductor	
		Min.	Max.	Min.	Max.	Min.	Max.	Min.	Max.
2	AEIC CS8-00								
	ICEA S-97-682-2000								
1	AEIC CS8-00								
	ICEA S-97-682-2000								
1/0	AEIC CS8-00	1.045	1.105	1.095	1.155	1.080	1.140	1.055	1.115
	ICEA S-97-682-2000	1.010	1.110	1.055	1.155	1.045	1.145	1.020	1.120
2/0	AEIC CS8-00			1.140	1.200	1.125	1.185	1.095	1.155
	ICEA S-97-682-2000			1.105	1.200	1.090	1.190	1.060	1.160
3/0	AEIC CS8-00			1.190	1.250	1.175	1.235	1.145	1.205
	ICEA S-97-682-2000			1.155	1.255	1.140	1.240	1.105	1.205
4/0	AEIC CS8-00			1.250	1.310	1.230	1.290	1.195	1.255
	ICEA S-97-682-2000			1.210	1.310	1.195	1.295	1.160	1.260
250	AEIC CS8-00			1.320	1.380	1.305	1.365	1.265	1.325
	ICEA S-97-682-2000			1.265	1.370	1.250	1.350	1.210	1.315
350	AEIC CS8-00			1.425	1.485	1.405	1.465	1.360	1.420
	ICEA S-97-682-2000			1.375	1.475	1.355	1.455	1.310	1.410
500	AEIC CS8-00			1.560	1.620	1.535	1.595	1.480	1.540
	ICEA S-97-682-2000			1.505	1.605	1.480	1.580	1.430	1.530
600	AEIC CS8-00			1.650	1.710	1.620	1.680	1.570	1.630
	ICEA S-97-682-2000			1.595	1.695	1.565	1.670	1.515	1.615
700	AEIC CS8-00			1.720	1.780	1.690	1.750	1.630	1.690
	ICEA S-97-682-2000			1.665	1.765	1.635	1.740	1.575	1.680
750	AEIC CS8-00			1.755	1.815	1.725	1.785	1.665	1.725
	ICEA S-97-682-2000			1.700	1.800	1.670	1.770	1.610	1.710
800	AEIC CS8-00			1.785	1.845	1.755	1.815	1.695	1.755
	ICEA S-97-682-2000			1.730	1.835	1.700	1.805	1.640	1.740
900	AEIC CS8-00			1.850	1.910	1.815	1.875	1.755	1.815
	ICEA S-97-682-2000			1.795	1.895	1.760	1.865	1.700	1.800
1000	AEIC CS8-00			1.905	1.965	1.870	1.930	1.815	1.875
	ICEA S-97-682-2000			1.850	1.955	1.815	1.920	1.760	1.865

CABLE CONDUCTOR DIAMETER REFERENCE

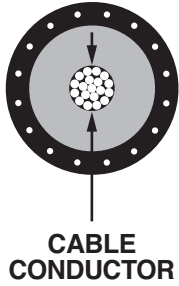







Conductor Diameters for Copper and Aluminum (Class B) Stranded, Compressed, Compact and Solid Cables

Conductor Size AWG or kcmil	No. of Strands and their Nom. Strand Dia. (in.)	Cross-sectional Area		Stranded Conductors (Inches)	Compressed Conductors (Inches)	Compact Conductors (Inches)	Solid Conductors (Inches)
		Square Inches	mm ² Conversion				
14	7 x .0242	.0032	2.08	.073	—	—	.064
12	7 x .0305	.0051	3.31	.092	—	—	.081
10	7 x .0385	.0082	5.26	.116	—	—	.102
8	7 x .0486	.0130	8.37	.146	—	—	.129
6	7 x .0612	.0206	13.30	.184	—	—	.162
4	7 x .0772	.0328	21.15	.232	—	—	.204
2	7 x .0974	.0521	33.62	.292	.283	.268	.258
1	19 x .0664	.0657	42.41	.332	.322	.299	.289
1/0	19 x .0745	.0829	53.49	.373	.362	.336	.325
2/0	19 x .0837	.1054	67.43	.418	.405	.376	—
3/0	19 x .0940	.1318	85.01	.470	.456	.423	—
4/0	19 x .1055	.1662	107.2	.528	.512	.475	—
250	37 x .0822	.1964	127	.575	.558	.520	—
350	37 x .0973	.2749	177	.681	.661	.616	—
500	37 x .1162	.3924	253	.813	.789	.736	—
600	61 x .0992	.4712	304	.893	.866	.813	—
700	61 x .1071	.5498	355	.964	.935	.877	—
750	61 x .1109	.5890	380	.998	.968	.908	—
800	61 x .1145	.6283	405	1.031	1.000	.938	—
900	61 x .1215	.7069	456	1.094	1.061	.999	—
1000	61 x .1280	.7854	507	1.152	1.117	1.060	—
1100	91 x .1099	.8639	557	1.209	1.173	—	—
1200	91 x .1148	.9425	608	1.263	1.225	—	—
1250	91 x .1172	.9818	633	1.289	1.250	—	—
1300	91 x .1195	1.021	659	1.315	1.276	—	—
1400	91 x .1240	1.100	709	1.364	1.323	—	—
1500	91 x .1284	1.178	760	1.412	1.370	—	—
1600	127 x .1122	1.257	811	1.459	1.415	—	—
1700	127 x .1157	1.335	861	1.504	1.459	—	—
1750	127 x .1174	1.374	887	1.526	1.480	—	—
1800	127 x .1191	1.414	912	1.548	1.502	—	—
1900	127 x .1223	1.492	963	1.590	1.542	—	—
2000	127 x .1225	1.571	1010	1.632	1.583	—	—

EQUIPMENT BUSHINGS

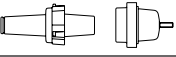
Elastimold manufactures a complete line of 200 Amp deepwell and 600 Series apparatus bushings for use on transformers, switchgear and other equipment applications. The bushings incorporate IEEE 386 standard interfaces (shown on page 3) and are constructed of molded epoxy with stainless steel flanges for mounting by welding or gasketed clamp. K1601PCC series bushings are provided with a

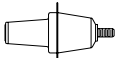
molded epoxy flange for gasketed clamp mounting only. Bushings are available for use on AIR, OIL or SF6 insulated equipment. Units are rated for submersible, padmount, indoor, outdoor and other applications. Options include hold-down bail tabs and replaceable studs for 200 Amp deepwell bushings.

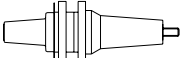
Illustration (not to scale)	Description	Voltage Class	ELASTIMOLD Part Number	Bushing Shank Length	Notes
	Short Shank Well with bail tabs and non-replaceable well stud	15/25kV 35kV	K1601PC-S1 L1601PC-S1	2 ³ / ₄ "	N3,7,14
	Short Shank Well with bail tabs and with replaceable well stud	15/25kV 35kV	K1601PC-S1-R L1601PC-S1-R	2 ³ / ₄ "	N1,3,7,14
	Short Shank Well without bail tabs and non-replaceable well stud	15/25kV 35kV	K1601PC-S2 L1601PC-S2	2 ³ / ₄ "	N3,7,14
	Short Shank Well without bail tabs and with replaceable well stud	15/25kV 35kV	K1601PC-S2-R L1601PC-S2-R	2 ³ / ₄ "	N1,3,7,14
	Long Shank Well with bail tabs and non-replaceable well stud	15/25kV 35kV	K1601PC-T1 L1601PC-T1	9 ¹ / ₄ "	N3,7,14
	Long Shank Well with bail tabs and with replaceable well stud	15/25kV 35kV	K1601PC-T1-R L1601PC-T1-R	9 ¹ / ₄ "	N1,3,7,14
	Long Shank Well without bail tabs and non-replaceable well stud	15/25kV 35kV	K1601PC-T2 L1601PC-T2	9 ¹ / ₄ "	N3,7,14
	Long Shank Well without bail tabs and with replaceable well stud	15/25kV 35kV	K1601PC-T2-R L1601PC-T2-R	9 ¹ / ₄ "	N1,3,7,14
	Epoxy Flange Well with replaceable well stud	15/25kV	K1601PCC-R		N1,3,7,14
	Well w/Insert (K1601PCC-R & 1601A4) Well w/Insert (K1601PCC-R & 2701A4)	15kV 25kV	1601CABA4R 2701CABA4R	2 ³ / ₄ "	N1,3,8,14 N1,3,9,14
	200 A Deadbreak Bushing	15/25kV	K180S4	2 ⁹ / ₁₆ "	N3,10,13
	200 A Deadbreak Bushing	15/25kV	K180T4	7 ¹¹ / ₃₂ "	
	200 A Deadbreak Bushing	15/25kV	K180C4	9 ¹ / ₄ "	
	600 A Short Shank Bushing w.o./stud	15/25kV	K650S1	2 ¹⁵ / ₁₆ "	N2,5,11,14,15 N2,5,12,14,16 N3,5,11,14,15
	600 A Short Shank Bushing w.o./stud	35kV	750S1		
	600 A Cu Short Shank Bushing w.o./stud	15/25kV	K675S1		
	600 A Long Shank Bushing w.o./stud	15/25kV	K650T1	8 ⁹ / ₁₆ "	N2,5,11,14,15 N3,5,11,14,15 N2,5,12,14,16 N2,5,12,14,16
	600 A Cu Long Shank Bushing w.o./stud	15/25kV	K675T1	8 ⁹ / ₁₆ "	
	600 A Long Shank Bushing w.o./stud	35kV	750T1	8 ⁹ / ₁₆ "	
	600 A 12" Long Shank Bushing w.o./stud	35kV	750L12	12"	
	600 A In-Air Long Shank Bushing w.o./stud	15/25kV	K650TBC	8 ⁹ / ₁₆ "	N2,4,11,6,14 N3,5,11,6,14 N6
	600 A Cu In-Air Long Shank Bush. w/stud	15/25kV	K675TBC		
	Boot & Collars for K600T1 to use in air	15/25kV	600BC		

- N1. Replacement stud available separately. Specify 1601RS.
- N2. Equipped with standard aluminum conductor rod.
- N3. Equipped with copper conductor rod.
- N4. Includes 5/8-11 threaded stud at elbow end.
- N5. Includes 5/8-11 threaded hole at elbow end.
- N6. Provides increased creep and strike.
- N7. Includes 1601PPC1 shipping cap.
- N8. Includes 1601APC1 shipping cap.
- N9. Includes 2701-41 shipping cap.
- N10. Includes 180PPC shipping cap.

- N11. Includes 650PPC shipping cap.
- N12. Includes 750PPC1 shipping cap.
- N13. Parking stands for 200A deadbreak applications are available as separate items. Specify 151PS.
- N14. Parking stands for 200A loadbreak and 600A deadbreak applications are available as separate items. Specify 160PS.
- N15. Aluminum stud available separately. Specify 650SA.
- N16. Copper stud available separately. Specify 750SA.

SP2 Index

Base Catalog Number	Page
00400X	7
0070X	25
0100X	25
0110X	25
02500X	7,9
02509X	7
02702X	7,9
02800X	7
03600X	17
03602X	17
03700X	11,15,17,19
03702X	11,15,17,19
10EP-W	7,9
10TL-W	31
150BA	9
150TB1	9
150TB2	9
150TB3	9
150TB4	9
150TB5	9
151GP	9
152EA-W	9
1535AFB-1	27
1535AFB-3	27
1535AFB-4	27
1535AFB-5	27
156LRF	9
156LR-W5X	9
15PCJ1FX	23
15PCJ1GX	23
15PCJ1HX	23
15PCJ1JX	23
15PCJ1KX	23
15PCJ1LMX	23
15PCJ1LX	23
15PCJ1MX	23
15PCJ1NX	23
15PCJ1PX	23
15PCJ1QX	23
15PCJ2FX	23
15PCJ2GX	23
15PCJ2HX	23
15PCJ2JX	23
15PCJ2KX	23
15PCJ2LX	23
15PCJ2MX	23
15PCJ2NX	23
15PCJ2PX	23
15PCJ2QX	23
1601A4	5
1601CABA4R	41
1601EA4	5

Base Catalog Number	Page
1602A3R	5
160CA-W	7,9
160DR	5
160DRG	5
160GLR	5,15,17
161GP	5
161SOP	5
164FT	5
164FTV	5
164J2	7
164J2-5	7
164J3	7
164J3-5	7
164J4	7
164J4-5	7
165LRJS-W5X	5
165LR-W5X	5
166LRF	7
166LRJS-W5X	5
166LR-W5X	5
167BSA-10	29
167BSA-12	29
167BSA-15	29
167BSA-18	29
167BSA-3	29
167BSA-6	29
167DRG	5
167ELR-W5X	5
167ESA-10	29
167ESA-12	29
167ESA-15	29
167ESA-18	29
167ESA-3	29
167ESA-6	29
167LRT-W5X	5
167PSA-10	29
167PSA-12	29
167PSA-15	29
167PSA-18	29
167PSA-3	29
167PSA-6	29
167RLR-W5X	5
168DRG	5
168ELR-W5X	5
168FLR-W0X	5
168RLR-W5X	5
16CAS-X	25
16TB-2	27
16TB-3	27
16TB-4	27
16TB-5	27
16TCA-X	25

Base Catalog Number	Page
16THGH-W	25
16THGS-WX	25
16THG-WX-4	25
200AT	5
200ECS	31
200ECSG1-2	31
200ECSG2-2	31
200ECSG3	31
20MA-W	31
21MA-W	31
25PCJ1GX	23
25PCJ1HX	23
25PCJ1JX	23
25PCJ1KX	23
25PCJ1LMX	23
25PCJ1LX	23
25PCJ1MX	23
25PCJ1NX	23
25PCJ1PX	23
25PCJ1QX	23
25PCJ2GX	23
25PCJ2HX	23
25PCJ2JX	23
25PCJ2KX	23
25PCJ2LX	23
25PCJ2MX	23
25PCJ2NX	23
25PCJ2PX	23
25PCJ2QX	23
2701A4	5
2701CABA4R	41
2701EA4	5
2702A1	5
272GP	5
272SOP	5
273BSA-10	29
273BSA-12	29
273BSA-15	29
273BSA-18	29
273BSA-21	29
273DRG	5
273ESA-10	29
273ESA-12	29
273ESA-15	29
273ESA-18	29
273ESA-21	29
273PSA-10	29
273PSA-12	29
273PSA-15	29
273PSA-18	29
273PSA-21	29
273RLR-W5X	5

SP2 Index

Base Catalog Number	Page
274DRG	5
274ELR-W5X	5
274FT	5
274FTV	5
274J2	7
274J2-5	7
274J3	7
274J3-5	7
274J4	7
274J4-5	7
274LRF	7
274RLR-W5X	5
275LRJS-W5X	5
275LR-W5X	5
276BWP	5
276LRJS-W5X	5
276LR-W5X	5
35AL-A	25
35MG-W	25
35MSCI-W	25
35MSC-W	25
35MTB1-A	27
35MTB1-B	27
35MTB1-C	27
35MTB1-D	27
35MTB3-A	27
35MTB3-B	27
35MTB3-C	27
35MTB3-D	27
35MTB4-A	27
35MTB4-B	27
35MTB4-C	27
35MTB4-D	27
35MTB5-A	27
35MTB5-B	27
35MTB5-C	27
35MTB5-D	27
35MTGA-WX-1	25
35MTGA-WX-2	25
35MTGA-WX-3	25
35MTGA-WX-4	25
35MTGI-W-4	25
35MTGI-W-6	25
35MTGI-W-8	25
35MTG-WX-10-CA	25
35MTG-WX-4-CA	25
35MTG-WX-8-CA	25
35PCJ1HX	23
35PCJ1JX	23
35PCJ1KX	23
35PCJ1LX	23
35PCJ1MX	23

Base Catalog Number	Page
35PCJ1NX	23
35PCJ1PX	23
35PCJ1QX	23
35PCJ2HX	23
35PCJ2JX	23
35PCJ2KX	23
35PCJ2LX	23
35PCJ2MX	23
35PCJ2NX	23
35PCJ2PX	23
35PCJ2QX	23
3701A3	5
3701A4	5
3702A1	5
370GLR	5,15,17
370TR	5,15,17
372SOP	5
373FT	5
373FTV	5
373J2	7
373J2-5	7
373J3	7
373J3-5	7
373J4	7
373J4-5	7
375BSA-24	29
375BSA-27	29
375BSA-30	29
375DRG	5
375ESA-24	29
375ESA-27	29
375ESA-30	29
375LR-W5X	5
375LRF	7
375PSA-24	29
375PSA-27	29
375PSA-30	29
376DRG	5
376LR-W5X	5
600AT	15,17
600ATM	11,13,17
600BC	41
600ECS	31
600ECSG1-2	31
600ECSG2-2	31
600ECSG3	31
600SW	11,13
600YADT	19
650AB	15
650ABV	15
650ARR-X	11,19
650BA	19

Base Catalog Number	Page
650BAW	19
650BEA3	17
650CAB	15
650CAM-OK	15
650ET	17
650ETP	11,17
650GP	11
650LINK-OK	15
650LK-C-VB	15
650LRTPA3	17
650LT-B	15
650RS	15
650RSC	15
650SA	11
650STICK-OK	17
650VSA	11
650WINDOW-OK	17
650YGDR	19
650YGP	19
655BI-LINK-B-LR-WOX-DRG	15
655BI-LINK-C-LR-WOX-DRG	15
655CA-W	11,19
655CK-W0X	11,15,17
655CK-W0X-ARR	11
655ETP-W0X-DRG	17
655LINK-B-LR-WOX-A-DRG	15
655LINK-B-LR-WOX-B-DRG	15
655LINK-C-LR-WOX-A-DRG	15
655LINK-C-LR-WOX-B-DRG	15
655LRTP-W0X-DRG	17
655TCK-W0X	17
750BEA2	17
750BIP	11
750CAB	15
750CAM-OK	15
750ETP	11,17
750GP	11
750J2	11
750J3	11
750J4	11
750LB	15
750LBM-3	15
750LINK-OK	15
750LK-C-VB	15
750LRTPA2	17
750LT-B	15
750S1	41
750SA	11
750SOP	11
750STICK-OK	17
750VSA	11
750WINDOW-OK	17

SP2 Index

Base Catalog Number	Page
755BE	11
755BI-LINK-B-LR-WOX-DRG	15
755BI-LINK-C-LR-WOX-DRG	15
755BLR	11
755BVS	11
755CA-W	11
755CK-WOX	11,15,17
755CK-WOX-ARR	11
755ETP-WOX-DRG	17
755L1	13
755L2	13
755L3	13
755L4	13
755LINK-B-LR-WOX-A-DRG	15
755LINK-B-LR-WOX-B-DRG	15
755LINK-C-LR-WOX-A-DRG	15
755LINK-C-LR-WOX-B-DRG	15
755LRTP-WOX-DRG	17
755LR-WOX	11
755TCK-WOX	17
755VSL2	13
755VSL3	13
755VSL4	13
756BLR	11
756LR-WOX	11
K1501A1	9
K1501FT	9
K1501J2-U	9
K1501J3-U	9
K1501J4-U	9
K1502A1	9
K150DP	9
K150DR	9
K150S	9
K150SOP	9
K150T	9
K151LS-W1X	9
K151LY-W1X	9
K151SP-WOX	9
K151SR-WOX	9
K1601PCC-R	41
K1601PC-S1	41
K1601PC-S1-R	41
K1601PC-S2	41
K1601PC-S2-R	41
K1601PC-T1	41
K1601PC-T1-R	41
K1601PC-T2	41
K1601PC-T2-R	41

Base Catalog Number	Page
K1601WFT	5
K1601WFTV	5
K1601WJ2	7
K1601WJ2-5	7
K1601WJ3	7
K1601WJ3-5	7
K1601WJ4	7
K1601WJ4-5	7
K180C4	41
K180S4	41
K180T4	41
K650BEA2	17
K650BIP	11
K650CAB	15
K650CAM-OK	15
K650CP	11
K650ETP	11,17
K650J2	11
K650J3	11
K650J4	11
K650LB	15
K650LBM-3	15
K650LINK-OK	15
K650LK-C-VB	15
K650LRTPA2	17
K650LT-B	15
K650RTP	11
K650RTW	11
K650S1	41
K650SOP	11
K650SRA	11
K650STICK-OK	17
K650T1	41
K650WINDOW-OK	17
K650YBIP	19
K655BE	11
K655BI-LINK-B-LR-WOX-DRG	15
K655BI-LINK-C-LR-WOX-DRG	15
K655BLR	11
K655BSR	11
K655BVS	11
K655ETP-WOX-DRG	17
K655L1	13
K655L2	13
K655L3	13
K655L4	13
K655LINK-B-LR-WOX-A-DRG	15
K655LINK-B-LR-WOX-B-DRG	15
K655LINK-C-LR-WOX-A-DRG	15

Base Catalog Number	Page
K655LINK-C-LR-WOX-B-DRG	15
K655LRTP-WOX-DRG	17
K655LR-WOX	11
K655SR-WOX	11
K655VSL2	13
K655VSL3	13
K655VSL4	13
K655YBSR	19
K655YDR	19
K655YSR-WOX	19
K656BLR	11
K656CH-BUS	19
K656CH-HP	19
K656CH-WOX	19
K656CY-BUS	19
K656CY-HP	19
K656CY-WOX	19
K656DR	11
K656I-BUS	19
K656I-HP	19
K656I-WOX	19
K656LR-WOX	11
K675S1	41
K675T1	41
K675TBC	41
L1601PC-S1	41
L1601PC-S1-R	41
L1601PC-S2	41
L1601PC-S2-R	41
L1601PC-T1	41
L1601PC-T2	41
L1601PC-T2-R	41
M276BWP	5
PB-1	27
PCT1-1X-4	25
PCT1-4	25
PCT2-1X-4	25
PCT2-4	25



POWER DELIVERY

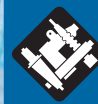

elastimold®

Thomas & Betts

Thomas & Betts Corporation
8155 T&B Blvd.
Memphis, TN 38125
Tel: (800) 888-0211
Fax: (800) 888-0690
www.tnb.com

PG-CA-0506
©2006 Thomas & Betts